

**CHAPTER 105. MECHANICAL, ELECTRICAL AND ELECTRONIC SPEED-TIMING DEVICES**

Subchap.	Sec.
A. GENERAL PROVISIONS .....	105.1
B. ELECTRONIC DEVICES (RADAR) .....	105.11
C. SPEEDOMETERS .....	105.31
D. ELECTRONIC DEVICES (NONRADAR) WHICH MEASURE ELAPSED TIME BETWEEN TWO SENSORS .....	105.51
E. STOPWATCHES .....	105.71
F. ELECTRONIC DEVICES (NONRADAR) WHICH CALCULATE AVERAGE SPEED BETWEEN ANY TWO POINTS .....	105.91

**Authority**

The provisions of this Chapter 105 issued under the Vehicle Code, 75 Pa.C.S. §§ 3368 and 6103, unless otherwise noted.

**Source**

The provisions of this Chapter 105 adopted August 26, 1977, effective August 27, 1977, 7 Pa.B. 2422; compiled and republished August 1, 1980, effective August 2, 1980, 10 Pa.B. 3199, unless otherwise noted.

**Notes of Decisions**

The Department has reclassified VASCAR as an electronic speed-timing (non-radar) device and approved its use by any police officer. *Commonwealth v. Smolow*, 527 A.2d 131 (Pa. Super. 1987). (Court cited 16 Pa.B. 3160 (August 23, 1986).)

Local police were justified in using the VASCAR-plus device, since this and an earlier regulation consistently classified the device as electrical-mechanical, and the burden therefore was on appellant to provide expert or scientific evidence from which the trial court could determine whether the device was electronic or electrical. *Commonwealth v. Smolow*, 527 A.2d 131 (Pa. Super. 1987). (Court cited 15 Pa.B. 321 (January 26, 1985).)

**Subchapter A. GENERAL PROVISIONS**

Sec.  
105.1. Purpose.

**§ 105.1. Purpose.**

This chapter governs the calibrating and testing of mechanical, electrical and electronic speed-timing devices by stations appointed by the Department.

**Source**

The provisions of this § 105.1 adopted August 26, 1977, effective August 27, 1977, 7 Pa.B. 2422; amended August 18, 1978, effective August 19, 1978, 8 Pa.B. 2311; republished and compiled August 1, 1980, effective August 2, 1980, 10 Pa.B. 3199; amended January 15, 1982, effective January 16, 1982, 12 Pa.B. 299; amended March 30, 1984, effective March 31, 1984, 14 Pa.B. 1089; amended

August 22, 1986, effective August 23, 1986, 16 Pa.B. 3119; readopted December 4, 1987, effective December 5, 1987, 17 Pa.B. 5051. Immediately preceding text appears at serial page (111301).

### Subchapter B. ELECTRONIC DEVICES (RADAR)

Sec.

- 105.11. [Reserved].
- 105.12. [Reserved].
- 105.12a. Application of subchapter.
- 105.13. Operation of maintenance and calibration stations.
- 105.14. Required equipment.
- 105.15. Calibration and testing procedure.

#### Source

The provisions of this Subchapter B amended through January 14, 1982, effective January 16, 1982, 12 Pa.B. 299, unless otherwise noted. Immediately preceding text appears at serial pages (56472) to (56477) and (56480) to (56482).

#### Notes of Decisions

Since the former PennDot regulation, 67 Pa. Code § 337.25, classifying ESP Machine (utilizes two sensors taped across street, connected to processing and display unit, to measure vehicle speed) as an electrical or mechanical device, rather than electronic device, was an interpretive rather than legislative regulation, the Court was not bound thereby, the court concluded that the ESP Machine was an electronic device which could not be used by local police. *Commonwealth v. DePasquale*, 501 A.2d 626 (Pa. 1985).

### § 105.11. [Reserved].

#### Source

The provisions of this § 105.11 adopted August 26, 1977, effective August 27, 1977, 7 Pa.B. 2422; amended November 9, 1979, effective November 10, 1979, 9 Pa.B. 3748; amended May 30, 1980, effective May 31, 1980, 10 Pa.B. 2162; republished and compiled August 1, 1980, effective August 2, 1980, 10 Pa.B. 3199; amended January 15, 1982, effective January 16, 1982, 12 Pa.B. 299; reserved March 30, 1984, effective March 31, 1984, 14 Pa.B. 1089. Immediately preceding text appears at serial pages (68566) to (68567).

### § 105.12. [Reserved].

#### Source

The provisions of this § 105.12 adopted August 26, 1977, effective August 27, 1977, 7 Pa.B. 2422; amended December 1, 1978, effective December 2, 1978, 8 Pa.B. 3439; amended August 24, 1979, effective August 25, 1979, 9 Pa.B. 2893; republished and compiled August 1, 1980, effective August 2, 1980, 10 Pa.B. 3199; amended January 15, 1982, effective January 16, 1982, 12 Pa.B. 299; reserved March 30, 1984, effective March 31, 1984, 14 Pa.B. 1089. Immediately preceding text appears at serial page (68567).

**§ 105.12a. Application of subchapter.**

This subchapter governs the calibration and testing of electronic devices—RADAR—for use only by members of the State Police, under 75 Pa.C.S. § 3368(c)(2) (relating to speed timing devices).

**Source**

The provisions of this § 105.12a adopted February 17, 1989, effective February 18, 1989, 19 Pa.B. 640.

**§ 105.13. Operation of maintenance and calibration stations.**

(a) *Maintenance and calibration.* Maintenance and calibration of electronic devices shall be provided, as necessary, upon notice by the State Police.

(b) *Hours.* Stations for the maintenance and calibration of electronic devices shall be operated during a regular work week Monday through Friday during the hours of 8 a.m. to 5 p.m.

(c) *Personnel.* Every station for the maintenance and calibration of electronic devices shall employ on a full time basis:

(1) An electrical engineer.

(2) An associate engineer, or technician who possesses a valid FCC Radio Telephone or Radio Telegraph License—General, First or Second Class.

(d) *Presumption of accuracy.* Either the electrical engineer, associate engineer or technician shall be present at the time that the test is conducted. The certification that the electronic speed-timing device has been tested and found to be accurate shall create a presumption that the requirements of this subsection have been fulfilled. Adjustments and repairs shall be made in conformance with 47 CFR 90.433 (relating to operator requirements).

(e) [Reserved].

(f) *Damage to or loss of device.* The station for the maintenance and calibration of electronic devices is responsible for damages or losses of electronic devices while they are being serviced or calibrated.

**Source**

The provisions of this § 105.13 adopted August 26, 1977, effective August 27, 1977, 7 Pa.B. 2422; amended December 30, 1977, effective December 31, 1977, 7 Pa.B. 2982; republished and compiled August 1, 1980, effective August 2, 1980, 10 Pa.B. 3199; amended January 15, 1982, effective January 16, 1982, 12 Pa.B. 299; readopted December 4, 1987, effective December 5, 1987, 17 Pa.B. 5051; amended February 17, 1989, effective February 18, 1989, 19 Pa.B. 640. Immediately preceding text appears at serial pages (122744) to (122745).

**Notes of Decisions**

Commonwealth's reliance solely upon certificate of accuracy and calibration to prove that speed-timing device had been approved by Department was insufficient to establish element of speeding offense. *Commonwealth v. Kittelberger*, 616 A.2d 1 (Pa. Super. 1992).

**§ 105.14. Required equipment.**

The following equipment is required for the operation of a maintenance and calibration station. Suitable manufacturers and model numbers are listed, however, equivalent equipment or an alternative technique approved by the Communications Division, State Police is acceptable:

- (1) Power supply—Hewlett Packard Model 6177C.
- (2) Frequency counter—Hewlett Packard Model 5314A.
- (3) Power Meter and Thermistor Mounts—Hewlett Packard Models 432A, X486A and K486A.
- (4) Multimeter—Hewlett Packard Model 410C.
- (5) AC Voltmeter—Hewlett Packard Model 400D or Leader Model LMV-181A.
- (6) Function Generator—Hewlett Packard Model 3311A.
- (7) Variable Attenuators—Hewlett Packard Models X382A and K382A.
- (8) RF Absorption Chamber—See Appendix A, Figure 1.
- (9) Frequency Counter—Hewlett Packard Models 5342A or 5343A.
- (10) Calibrated Antennas—Narda Models 638 and 640.
- (11) Coaxial Adapters—Narda Models 4601 and 4608B.
- (12) Pin Diode Switch—General Microwave F9114.
- (13) Microphone—Electrovoice 631A.
- (14) 4 Watt HF or VHF—AM Modulated Signal Source.
- (15) Base Loaded Whip Antenna Tuned to paragraph (14).

**Source**

The provisions of this § 105.14 adopted August 26, 1977, effective August 27, 1977, 7 Pa.B. 2422; republished and compiled August 1, 1980, effective August 2, 1980, 10 Pa.B. 3199; amended January 15, 1982, effective January 16, 1982, 12 Pa.B. 299; readopted December 4, 1987, effective December 5, 1987, 17 Pa.B. 5051; amended February 17, 1989, effective February 18, 1989, 19 Pa.B. 640. Immediately preceding text appears at serial pages (122745) to (122748).

**§ 105.15. Calibration and testing procedure.**

- (a) *General.* An electronic device shall be calibrated and tested as follows:
  - (1) *Power output.* Relative power output shall be measured in the following manner:
    - (i) Adjust dc power supply to 13.6 vdc.
    - (ii) With equipment still connected as in Appendix A, Figure 2, position (1), position antenna system along each axis for maximum coupling. Simultaneously increase attenuation to avoid overloading the thermister amount.
    - (iii) Adjust microwave variable attenuator for maximum attenuation and then calibrate microwave power meter.
    - (iv) Reduce attenuation until microwave power meter reads 0 dB.

- (v) Calculate power output taking into consideration the gain of the horn, and attenuation of the microwave variable attenuator, added algebraically with the power level indicated on the power meter.

Example:

Attenuator	33.6 dB
Power Meter Reading	<u>0.0 dB</u>
	33.6 dB
Gain of Horn	<u>-16.7 dB</u>
Relative Power	16.9 dB = 48.98 mW

(2) *Transmitted frequency.* Transmitted frequency shall be measured in the following manner:

- (i) Adjust variable dc power supply to 13.6 vdc.
- (ii) With the equipment connected as in Appendix A, Figure 2, position (2) adjust the microwave variable attenuator for a stable readout on frequency counter.
- (iii) Record transmitter frequency as indicated on the microwave frequency counter. Frequency shall be within .2% of licensed frequency.
- (iv) Vary the applied voltage from 11 vdc to 14 vdc. Frequency shall remain within .2% of licensed frequency.

(3) *Stability test.* The stability test shall be conducted in the following manner:

- (i) Adjust variable dc power supply to 13.6 vdc.
- (ii) Connect equipment as in Appendix A, Figure 2, position (3).
- (iii) Adjust square wave output of function generator to the switching level of the pin diode switch. While observing the frequency counter, adjust frequency of function generator to 1726 Hz (X-Band) or 3961 Hz (K-Band) or 5692 Hz (Ka-Band).
- (iv) Vary applied dc voltage from 11 vdc to 14 vdc while observing indicated speed on device being tested. Indicated speed may not vary.

(4) *Relative sensitivity.* Relative sensitivity shall be measured in the following manner:

- (i) Adjust variable dc power supply to 13.6 vdc.
- (ii) Connect equipment as in Appendix A, Figure 2, position (3).
- (iii) Adjust range control if applicable on electronic device for maximum range.
- (iv) Adjust square wave output of function generator, to switching level of pin diode modulator. While observing frequency counter, adjust frequency of function generator so that device being tested indicates 55 mph.
- (v) Slowly increase attenuation of microwave variable attenuator, until speed reading of 55 mph of device being tested becomes erratic.
- (vi) Readjust position of device for maximum coupling.

(vii) Repeat steps in subparagraphs (v) and (vi) until no further increase is possible, without losing display. Maximum coupling is imperative.

(viii) Calculate relative sensitivity of device being tested, taking into consideration attenuation or gain of each component in the microwave path. The reflected signal passes through devices two times therefore values shall be multiplied by two.

*Example:*

Gain of Horn	16.7 dB x 2	+33.4 dB
Attenuation	33 dB x 2	-66 dB
Relative Sensitivity		-32.6 dB

(5) *Accuracy test.* The accuracy test shall be conducted in the following manner:

- (i) Adjust variable dc power supply to 13.6 vdc.
- (ii) Connect equipment as in Appendix A, Figure 2, position (3).
- (iii) Adjust square wave output of function generator, to switching level of pin diode modulator. While observing frequency counter, adjust function generator for an indicated speed of 55 mph.
- (iv) Adjust microwave variable attenuator and range control for stable display.
- (v) While observing the frequency counter, adjust the function generator to each test frequency. Note and record the speed indicated on the electronic device display. Each test frequency shall produce the correct speed in mph within the limits of +0, -1 mph.

*Test Frequencies (in Hz)*

<i>X Band</i>	<i>K Band</i>	<i>Ka Band</i>	<i>Indicated Test Speed mph</i>
628	1440	2070	20
785	1801	2588	25
942	2161	3105	30
1099	2521	3622	35
1256	2881	4140	40
1412	3241	4657	45
1569	3601	5175	50
1726	3961	5692	55
1883	4321	6210	60
2040	4681	6727	65
2197	5042	7246	70
2354	5402	7762	75
2511	5762	8281	80
2668	6122	8797	85

<i>X Band</i>	<i>K Band</i>	<i>Ka Band</i>	<i>Indicated Test Speed mph</i>
2825	6482	9316	90
2982	6842	9832	95
3139	7202	10351	100
3296	7562	10867	105
3453	7922	11385	110
3610	8283	11902	115
3767	8643	12420	120
3924	9003	12937	125
4081	9363	13455	130
4238	9723	13972	135
4394	10083	14490	140

(6) *Tuning fork test.* The tuning fork test shall be conducted in the following manner:

(i) Connect the microphone, ac voltmeter and frequency counter as depicted in Appendix A, Figure 2.

(ii) Strike the tuning fork on a block of wood and hold the vibrating tuning fork close to the microphone.

(iii) Adjust the gain of the audio amplifier for a stable display on the frequency counter.

(iv) Note the displayed frequency on the frequency counter and convert it into miles per hour. The calculated speed shall be the same as that indicated on the tuning fork or within 1%. The tuning fork shall be at room temperature, or approximately 70° F., when this measurement is taken.

(v) Strike the tuning fork on a block of wood and hold it close to the device antenna. The indicated speed shall be stable, and shall be that of the tuning fork.

(7) *Rejection of extraneous RF fields.*

(i) Adjust variable dc power supply to 13.6 vdc.

(ii) Position the base loaded antenna 1 meter from the radar assembly.

(iii) Activate the 4 watt signal source, modulated at 100%, 1726 Hz (X-Band) or 3961 Hz (K-Band) or 5692 Hz (Ka-Band).

(iv) There may be no readout on the electronic device indicator, related to the extraneous RF field.

(b) *Maintenance work-order.* A maintenance work-order containing the following information shall be completed and forwarded to the Communications Division:

(1) Serial number of the electronic device.

(2) Work performed and date of same.

(3) Original complaint, if any.

(4) Actual repairs performed, if any.

- (5) Amount of time taken to repair unit.
- (6) Manufacturer's stock number of all equipment replaced.
- (7) Total labor cost.
- (8) Individual part prices for all equipment replaced.
- (9) The name and address, class, serial number and expiration date of the operator's license of the individual conducting the test. The testing individual shall also sign and date the maintenance work order. Maintenance performed shall conform with FCC rules and regulations pertaining to radio location devices.

(c) *Certificates of accuracy.* These forms, provided by the Department, shall be filed for each electronic device calibrated and tested.

- (1) Original shall be filed at the State Police station.
- (2) One duplicate copy shall be retained by the maintenance and calibration station for at least 2 years.
- (3) One duplicate copy shall be forwarded to the Communications Division, State Police.
- (4) One duplicate copy shall accompany the electronic device.
- (5) A duplicate copy, executed and signed in the same manner as the original, has the same force and effect as the original.

(d) *Electronic device—radar—calibration.* Technical data forms provided by the State Police Communications Division, shall be filed for each electronic device calibrated and tested.

- (1) One original shall be forwarded to the Communications Division, State Police.
- (2) One duplicate copy shall be retained by the maintenance and calibration station for at least 2 years.
- (3) A duplicate copy, executed and signed in the same manner as the original, has the same force and effect as the original.

#### Source

The provisions of this § 105.15 adopted August 26, 1977, effective August 27, 1977, 7 Pa.B. 2422; corrected September 2, 1977, effective August 27, 1977, 7 Pa.B. 2564; amended August 18, 1978, effective August 19, 1978, 8 Pa.B. 2310; amended August 18, 1978, effective August 19, 1978, 8 Pa.B. 2310; republished and compiled August 1, 1980, effective August 2, 1980, 10 Pa.B. 3199; amended January 15, 1982, effective January 16, 1982, 12 Pa.B. 299; amended June 18, 1982, effective June 19, 1982, 12 Pa.B. 1875; corrected June 29, 1984, effective January 16, 1982, 14 Pa.B. 2267; readopted December 4, 1987, effective December 5, 1987, 17 Pa.B. 5051; amended February 17, 1989, effective February 18, 1989, 19 Pa.B. 640; amended July 31, 1998, effective August 1, 1998, 28 Pa.B. 3588. Immediately preceding text appears at serial pages (218210) to (218214).



**Subchapter C. SPEEDOMETERS**

- Sec.  
105.31. Appointment of speedometer testing station.  
105.32. Operation of speedometer testing station.  
105.33. Required equipment.  
105.34. Manner of testing speedometers.  
105.35. [Reserved].

**§ 105.31. Appointment of speedometer testing station.**

(a) *Application.* Application for appointment as a speedometer testing station or mobile testing unit to be operated by a speedometer testing station shall be made on a form provided by the Department and submitted for each speedometer testing station and each mobile testing unit to be operated by a speedometer testing station.

(b) *Applicant.* Each applicant intending to be appointed as a speedometer testing station or mobile testing unit to be operated by a speedometer testing station that is not a business entity, including a sole proprietor or partner in a general or limited partnership, shall be at least 18 years of age.

(c) *Place of business.* An applicant shall have an established place of business properly equipped to conduct speedometer tests and repairs or to operate as an approved mobile testing unit.

(d) *Certificate of Appointment.* A speedometer testing station and each mobile testing unit operated by a speedometer testing station shall prominently display a valid Certificate of Appointment provided by the Department.

**Source**

The provisions of this § 105.31 adopted August 26, 1977, effective August 27, 1977, 7 Pa.B. 2422; republished and compiled August 1, 1980, effective August 2, 1980, 10 Pa.B. 3199; readopted December 4, 1987, effective December 5, 1987, 17 Pa.B. 5051; amended February 17, 1989, effective February 18, 1989, 19 Pa.B. 640; amended September 30, 2016, effective October 1, 2016, 46 Pa.B. 6126. Immediately preceding text appears at serial page (218215).

**§ 105.32. Operation of speedometer testing station.**

(a) *Testing and repair.* Testing and repair of speedometers shall be provided, as necessary, upon notice by the police.

(b) *Hours.* Speedometer testing stations shall be open for business, at a minimum, Monday through Friday during the hours of 8 a.m. to 5 p.m., except for legal holidays or alternative business hours approved in writing by the Department.

(c) *Personnel.* A speedometer testing station shall employ at least one technician certified as follows:

- (1) An application of a technician for certification shall be made on a form provided by the Department.

- (2) The applicant shall present proof of education or experience in the testing and repair of speedometers.
- (3) The applicant shall be at least 18 years of age.
- (d) *Location.* Speedometer testing and repair shall take place at an approved speedometer testing station, except that, upon application to and approval by the Department, a speedometer testing station may operate one or more mobile testing units of a type approved by the Department.

#### Source

The provisions of this § 105.32 adopted August 26, 1977, effective August 27, 1977, 7 Pa.B. 2422; republished and compiled August 1, 1980, effective August 2, 1980, 10 Pa.B. 3199; readopted December 4, 1987, effective December 5, 1987, 17 Pa.B. 5051; amended February 17, 1989, effective February 18, 1989, 19 Pa.B. 640; amended September 30, 2016, effective October 1, 2016, 46 Pa.B. 6126. Immediately preceding text appears at serial pages (218215) to (218216).

### § 105.33. Required equipment.

- (a) *Items.* A speedometer testing station or mobile testing unit shall have sufficient tools to make repairs or adjustments and one or more of the following required equipment:
  - (1) A dynamometer of a type approved by the Department.
  - (2) A Speed-Master Quartz Speedometer Tester.
  - (3) A 650-H-1 Stewart-Warner Speedometer Calibrator with adaptive equipment needed to operate this device or any device.
  - (4) Any equipment or alternative technique approved by the Department and published in the *Pennsylvania Bulletin*.
- (b) *Periodic testing of speedometer testing equipment.* Speedometer testing equipment shall be repaired, tested and adjusted for accuracy in accordance with the testing equipment manufacturer's specifications. If the testing equipment manufacturer does not specify a testing schedule, the speedometer testing equipment shall be tested and adjusted for accuracy at least once every 60 days.

#### Source

The provisions of this § 105.33 adopted August 26, 1977, effective August 27, 1977, 7 Pa.B. 2422; amended June 23, 1978, effective June 24, 1978, 8 Pa.B. 1692; republished and compiled August 1, 1980, effective August 2, 1980, 10 Pa.B. 3199; readopted December 4, 1987, effective December 5, 1987, 17 Pa.B. 5051; amended February 17, 1989, effective February 18, 1989, 19 Pa.B. 640; amended September 30, 2016, effective October 1, 2016, 46 Pa.B. 6126. Immediately preceding text appears at serial page (218216).

#### Cross References

This section cited in 67 Pa. Code § 105.34 (relating to manner of testing speedometers).

### § 105.34. Manner of testing speedometers.

- (a) *Accuracy.* A speedometer shall be tested for accuracy and, if necessary, repaired and adjusted to obtain the greatest possible degree of accuracy. Testing shall be conducted in accordance with the following:
  - (1) Testing equipment and alternative techniques set forth in or approved in accordance with § 105.33 (relating to required equipment) shall be used.

(2) Testing shall occur using manufacturer's specifications and procedures.

(3) It is necessary to have a measured or surveyed calibration course laid out and properly marked when using a technique that requires a calibration course for testing.

(b) *Forms.* A Certificate of Accuracy, on a form provided by the Department, shall be completed after a speedometer test or repair and signed by the certified technician that performed the speedometer test. The Certificate of Accuracy may be completed on an electronic fillable form provided by the Department and signed electronically by the certified technician. A copy of the certificate shall be kept on file at the speedometer testing station for at least 3 years, and be made available to the State Police or Department representatives, as necessary. Additional Certificates of Accuracy completed, executed and signed in the same manner as the original, have the same force and effect as the original.

**Source**

The provisions of this § 105.34 adopted August 26, 1977, effective August 27, 1977, 7 Pa.B. 2422; amended June 23, 1978, effective June 24, 1978, 8 Pa.B. 1692; republished and compiled August 1, 1980, effective August 2, 1980, 10 Pa.B. 3199; readopted December 4, 1987, effective December 5, 1987, 17 Pa.B. 5051; amended February 17, 1989, effective February 18, 1989, 19 Pa.B. 640; amended September 30, 2016, effective October 1, 2016, 46 Pa.B. 6126. Immediately preceding text appears at serial pages (218216) to (218218).

**§ 105.35. [Reserved].**

**Source**

The provisions of this § 105.35 adopted June 23, 1978, effective June 24, 1978, 8 Pa.B. 1692; amended October 27, 1978, effective October 28, 1978, 8 Pa.B. 2918; amended January 26, 1979, effective January 27, 1979, 9 Pa.B. 346; amended May 16, 1980, effective May 17, 1980, 10 Pa.B. 1980; republished and compiled August 1, 1980, effective August 2, 1980, 10 Pa.B. 3199; amended January 15, 1982, effective January 16, 1982, 12 Pa.B. 299; amended September 2, 1983, effective September 3, 1983, 13 Pa.B. 2705; amended December 30, 1983, effective December 31, 1983, 13 Pa.B. 4021; reserved March 30, 1984, effective March 31, 1984, 14 Pa.B. 1089. Immediately preceding text appears at serial pages (83717) to (83722).

**Subchapter D. ELECTRONIC DEVICES (NONRADAR) WHICH  
MEASURE ELAPSED TIME BETWEEN TWO SENSORS**

Sec.

105.51. [Reserved].

105.52. [Reserved].

105.52a. Application of subchapter.

105.53. Operation of maintenance and calibration stations.

105.54. Calibration forms.

105.55. Testing forms.

105.56. Manner of calibration and testing.

**Notes of Decisions**

Since the former PennDot regulation, 67 Pa. Code § 337.25, classifying ESP Machine (utilizes two sensors taped across street, connected to processing and display unit, to measure vehicle speed) as an electrical or mechanical device, rather than electronic device was an interpretive rather than legislative regulation, the Court was not bound thereby, the court concluded that the ESP Machine was an electronic device which could not be used by local police. *Commonwealth v. DePasquale*, 501 A.2d 626 (Pa. 1985).

**§ 105.51. [Reserved].****Source**

The provisions of this § 105.51 adopted June 23, 1978, effective June 24, 1978, 8 Pa.B. 1692; amended December 15, 1978, effective December 16, 1978, 8 Pa.B. 3578; amended May 18, 1979, effective May 19, 1979, 9 Pa.B. 1632; republished and compiled August 1, 1980, effective August 2, 1980, 10 Pa.B. 3199; amended November 12, 1982, effective November 13, 1982, 12 Pa.B. 3946; reserved March 30, 1984, effective March 31, 1984, 14 Pa.B. 1089. Immediately preceding text appears at serial page (83723).

**§ 105.52. [Reserved].****Source**

The provisions of this § 105.52 adopted June 23, 1978, effective June 24, 1978, 8 Pa.B. 1692; amended December 15, 1978, effective December 16, 1978, 8 Pa.B. 3578; amended September 28, 1979, effective September 29, 1979, 9 Pa.B. 3324; amended January 11, 1980, effective January 12, 1980, 10 Pa.B. 131; amended May 10, 1980, effective May 17, 1980, 10 Pa.B. 1980; amended May 30, 1980, effective May 31, 1980, 10 Pa.B. 2162; republished and compiled August 1, 1980, effective August 2, 1980, 10 Pa.B. 3199; amended October 17, 1980, effective October 18, 1980, 10 Pa.B. 4101; amended January 15, 1982, effective January 16, 1982, 12 Pa.B. 299; amended May 28, 1982, effective May 29, 1982, 12 Pa.B. 1698; amended November 12, 1982, effective November 13, 1982, 12 Pa.B. 3946; amended November 19, 1982, effective November 20, 1982, 12 Pa.B. 3983; amended September 2, 1983, effective September 3, 1983, 13 Pa.B. 2705; amended December 30, 1983, effective December 31, 1983, 13 Pa.B. 4021; reserved March 30, 1984, effective March 31, 1984, 14 Pa.B. 1089. Immediately preceding text appears at serial pages (83723) to (83724).

**§ 105.52a. Application of subchapter.**

This subchapter governs the calibrating and testing of electronic devices—nonradar—which measure elapsed time between two sensors, for use by a police officer, under 75 Pa.C.S. § 3368(c)(3) (relating to speed timing devices).

**Source**

The provisions of this § 105.52a adopted August 22, 1986, effective August 23, 1986, 16 Pa.B. 3119; readopted December 4, 1987, effective December 5, 1987, 17 Pa.B. 5051; amended February 17, 1989, effective February 18, 1989, 19 Pa.B. 640. Immediately preceding text appears at serial page (122758).

**§ 105.53. Operation of maintenance and calibration stations.**

(a) *Maintenance and calibration.* Maintenance and calibration of electronic devices governed by this subchapter shall be provided, as necessary, upon request by local police.

(b) *Hours.* Stations for the maintenance and calibration of electronic devices shall be operated during a regular work week, Monday through Friday during the hours of 8 a.m. to 5 p.m.

(c) *Personnel.* A station for the maintenance and calibration of electronic devices shall employ on a full-time basis:

- (1) An electrical engineer or metrologist.
- (2) An associate engineer, associate metrologist or technician.

(d) *Presumption of accuracy.* Either the electrical engineer, associate engineer, metrologist, associate metrologist or technician shall be present at the time the test is conducted. The certification that the electronic speed-timing device has been tested and found to be accurate shall create a presumption that the requirements of this subsection have been fulfilled.

(e) *Damage to or loss of device.* The station for the maintenance and calibration of electronic devices is responsible for damages or losses of electronic devices while they are being serviced or calibrated.

(f) *Malfunctioning devices.* A malfunctioning electronic device shall be returned to the manufacturer or to a service center approved by the manufacturer and tagged with the date tested, the serial number of the device and a notation of the general condition of the device.

(g) *Location.* Electronic testing and repair shall take place at an approved electronic testing station, except that, upon approval of the Department, an electronic testing station may operate mobile test units of a type approved by the Department.

**Source**

The provisions of this § 105.53 adopted June 23, 1978, effective June 24, 1978, 8 Pa.B. 1692; republished and compiled August 1, 1980, effective August 2, 1980, 10 Pa.B. 3199; amended August 22, 1986, effective August 23, 1986, 16 Pa.B. 3119; readopted December 4, 1987, effective December 5, 1987, 17 Pa.B. 5051; amended February 17, 1989, effective February 18, 1989, 19 Pa.B. 640. Immediately preceding text appears at serial page (122758).

**§ 105.54. Calibration forms.**

Certificates of accuracy, provided by the Department, shall be filed for electronic devices calibrated and tested as follows:

- (1) Original and duplicate shall accompany electronic device.
- (2) One duplicate copy shall be retained by the maintenance and calibration station for at least 2 years.
- (3) A duplicate copy, executed and signed in the same manner as the original, has the same force and effect as the original.

**Source**

The provisions of this § 105.54 adopted June 23, 1978, effective June 24, 1978, 8 Pa.B. 1692; republished and compiled August 1, 1980, effective August 2, 1980, 10 Pa.B. 3199; amended August 22, 1986, effective August 23, 1986, 16 Pa.B. 3119; readopted December 4, 1987, effective December 5, 1987, 17 Pa.B. 5051; amended February 17, 1989, effective February 18, 1989, 19 Pa.B. 640. Immediately preceding text appears at serial pages (122758) to (122759).

**§ 105.55. Testing forms.**

Technical data forms, provided by the Department, shall be filed for electronic devices tested as follows:

- (1) One original shall accompany the electronic device.
- (2) One duplicate copy shall be retained by the maintenance and calibration station for at least 2 years.
- (3) A duplicate copy, executed and signed in the same manner as the original, has the same force and effect as the original.

**Source**

The provisions of this § 105.55 adopted June 23, 1978, effective June 24, 1978, 8 Pa.B. 1692; republished and compiled August 1, 1980, effective August 2, 1980, 10 Pa.B. 3199; amended August 22, 1986, effective August 23, 1986, 16 Pa.B. 3119; readopted December 4, 1987, effective December 5, 1987, 17 Pa.B. 5051; amended February 17, 1989, effective February 18, 1989, 19 Pa.B. 640. Immediately preceding text appears at serial page (122759).

**§ 105.56. Manner of calibration and testing.**

(a) *Electrical Speed-Timing System*—Manufactured by Richard Hageman, 98 South Penn Dixie Road, Nazareth, Pennsylvania. Calibration requirements are as follows:

- (1) *Required equipment.* The following equipment or equivalent substitute equipment is required for calibration:
  - (i) USM 207 Universal Counter.
  - (ii) STALO E1010V.
  - (iii) Miscellaneous test leads.
- (2) *Calibration procedure.* (See Appendix A, Figure 3 for equipment set up.) The calibration procedure shall be as follows:
  - (i) Set counter (USM 207) to Time (B-C) Mode.
  - (ii) Throw start switch on USM 207 and Electrical Speed-Timing System will start at same time.
  - (iii) Switch start override on.
  - (iv) Throw stop switch, stopping USM 207 and Electrical Speed-Timing System at same time.
  - (v) Read and record elapsed time of both devices.
  - (vi) Miles per hour (mph) is calculated as follows:
    - (A) Feet per second = measured distance—in feet—divided by time elapsed—in seconds.

(B) mph = .6818 x feet per second.

(vii) If the readout on the face of the Electrical Speed-Timing System differs by more than 1 mph, the unit shall be returned to the manufacturer and tagged with the date tested, the serial number of the device and a notation of the general condition of the device.

(b) *Model TK 100, Excessive Speed Preventor (ESP)*—Manufactured by Systems Innovation, Inc., Steam Hollow Road, R.D. 2 and Hallstead Plaza, Route 11, Hallstead, Pennsylvania.

(1) *Required equipment.* The following equipment or an equivalent substitute is required for calibration:

(i) *Test Cable—Model TK 100-01.* Manufactured by Systems Innovation, Inc. (See Appendix A, Figure 4 for an equivalent substitute.)

(ii) *Power supply.* Voltage output—11 to 14 volts dc .5 amp. (See Appendix A, Figure 5).

(iii) *Frequency counter.* Data Precision—Model 5740 or equivalent. (See Appendix A, Figure 5).

(iv) *Digital delay generator.* Range: .1 ms to 800 ms; Accuracy: + or – .1%. (See Appendix A, Figure 6).

(2) *Calibration procedure.* The calibration procedure shall be as follows:

(i) Interconnect the ESP Model TK 100 as shown in Appendix A, Figure 6.

(ii) Place the ESP switches in the following positions:

(A) Power On/Off—Off.

(B) Auto/Lock—Auto.

(C) Start On 1/On 2—On 1.

(D) Alert On/Off—Either one.

(E) Set Alert—on or off.

(iii) Set the digital delay generator to the nearest .1 ms—.0001 sec.—using the following formula:

Delay time = 4091 divided by SPEED mph

*Example:* To check the ESP Accuracy at 50 mph, set the delay time as follows:

Delay Time = 4091 divided by 50 mph = 81.8 ms.

(iv) Place the ESP Power On/Off Switch to On. The ESP shall read 000.

(v) Check that the frequency counter reads 1,000,000 Hz + or –999 Hz.

(vi) Press the start switch and observe that the ESP reads within 1 mph of the desired test speed.

(vii) Check and record the ESP readings from 20 mph to 140 mph in 5 mph increments.

(viii) If the ESP failed one or more of the previous tests, it shall be returned to the manufacturer or to a service center approved by the manufacturer and tagged with the date tested, the serial number of the device and a notation of the general condition of the device.

- (ix) If the ESP has passed the previous tests, calibration is complete.
- (c) *Speed Chek*—(identified on the housing as Speed Chek model one, mfd. for: The Union Agency, Unionville, Pennsylvania 19375). Manufactured by Sterner Lighting Systems, Inc., 351 Lewis Avenue, Winsted, Minnesota.
- (1) *Required equipment.* (See Appendix A, Figure 7 for test setup). The following equipment is required for calibration:
- (i) Two pulse generators.
  - (ii) Dual channel oscilloscope or counter with interval capability.
  - (iii) Power supply—+5 volts.
- (2) *Calibration procedure.* (See Appendix A, Figure 8 for interconnection diagram). Calibration procedures shall be as follows:
- (i) A single circuit to generate the signals that simulate the front wheels of a vehicle crossing the tape switches shall be set up as set forth in Appendix A, Figures 5 and 6.
  - (ii) The elapsed time between the pulse on Outputs 1 and 2 is measured by the Speed Chek using the formula  $V \times T = 3408$ . 3408 is the proper constant for a 5-foot roadswitch spacing.  
 $V =$  velocity in mph  
 $T =$  time in ms
  - (iii) The elapsed interval time is computed by the equation:
 
$$V = \frac{3408}{T}$$
 and compared to the readout on the Speed Chek.
  - (iv) If the readout on the face of the Speed Chek differs by more than 1 mph, the unit shall be returned to the manufacturer or to a service center approved by the manufacturer and tagged with the date tested, the serial number of the device and a notation of the general condition of the device.
- (d) *Model TK 100, Excessive Speed Preventor (ESP) Infrared*—Manufactured by Systems Innovation, Inc., Steam Hollow Road, R. D. 2 and Hallstead Plaza, Route 11, Hallstead, Pennsylvania.
- (1) *Required equipment.* The following equipment or an equivalent substitute is required for calibration:
- (i) Test Cable—Model TK 100-01. Manufactured by Systems Innovation, Inc. (See Appendix A, Figure 4 for an equivalent substitute.)
  - (ii) Power supply. Voltage output—11 to 14 volts dc .5 amp.
  - (iii) Frequency counter. Data Precision—Model 5740 or equivalent.
  - (iv) Digital delay generator. Range: .1 ms to 800 ms; Accuracy: + or - .1%.
- (2) *Calibration procedure.* The calibration procedure shall be as follows:
- (i) Interconnect the ESP Model TK 100 Infrared as shown in Appendix A, Figure 6.



- (ii) Place the ESP Infrared switches in the following positions:
  - (A) Power On/Off—Off.
  - (B) Auto/Lock—Auto.
  - (C) Start On 1/On 2—On 1.
  - (D) Alert On/Off—either one.
  - (E) Set Alert—on or off.
- (iii) Set the digital delay generator to the nearest .1 ms—.0001 sec.—using the following formula:  
Delay time = 2045 divided by speed mph  
*Example:* To check the ESP Infrared Accuracy at 50 mph, set the delay time as follows:  
Delay time = 2045 divided by 50 mph = 40.9 ms.
  - (iv) Place the ESP Infrared Power On/Off Switch to On. The ESP Infrared shall read 000.
  - (v) Check that the frequency counter reads 1,000,000 Hz + or -999 Hz.
  - (vi) Press the start switch and observe that the ESP Infrared reads within 1 mph of the desired test speed.
  - (vii) Check and record the ESP Infrared readings from 20 mph to 140 mph in 5 mph increments.
  - (viii) Connect infrared sensors and turn on test panel switch.
  - (ix) Turn rotary switch to the 20 mph position and press test switch. Reading shall be within the tolerances of + 0 to -2 mph. Repeat for test speeds of 60 mph and 140 mph.
  - (x) If the ESP Infrared failed one or more of the previous tests, it shall be returned to the manufacturer or to a service center approved by the manufacturer and tagged with the date tested, the serial number of the device and a notation of the general condition of the device.
  - (xi) If the ESP Infrared has passed the previous tests, calibration is complete.
- (e) *Enradd, Model EJU-91*—Manufactured by Y.I.S., Incorporated, 1049 Hartley Street, P. O. Box 3044, York, Pennsylvania 17404.
  - (1) *Required equipment.* The following equipment or an equivalent substitute is required for calibration:
    - (i) Two pulse generators.
    - (ii) Dual channel oscilloscope or frequency counter with interval capability.
    - (iii) Power supply, + 5 volts.
  - (2) *Calibration procedure.* (See Appendix A, Figure 8 for interconnection diagram). Calibration procedures shall be as follows:
    - (i) A single circuit to generate the signals that simulate the front wheels of a vehicle crossing the road sensor shall be set up as set forth in Appendix A, Figure 7.

(ii) The elapsed time between the pulse on Outputs 1 and 2 is measured by the Enradd using the formula  $V \times T = 3408$ . 3408 is the proper constant for a 5-foot timing strip spacing.

V = velocity in mph

T = time in ms

(iii) The elapsed interval time is computed by:

(A) Calculation of the equation:

$$V = \frac{3408}{T}$$

T

(B) Comparison of the readout on the oscilloscope/frequency counter to the readout on the Enradd.

(iv) If the readout on the face of the Enradd differs by more than  $\pm 1$  mph, the unit shall be returned to the manufacturer or to a service center approved by the manufacturer and tagged with the date tested, the serial number of the device and a notation of the general condition of the device.

(f) *Equipment, timing strips and other devices.* The calibration and testing of equipment, timing strips and other devices actually used with a particular electronic device—nonradar—shall be performed under specifications provided by the manufacturer of an approved device using equipment specified by the manufacturer or equivalent substitute equipment.

#### Source

The provisions of this § 105.56 adopted December 15, 1978, effective December 16, 1978, 8 Pa.B. 3578; amended May 18, 1979, effective May 19, 1979, 9 Pa.B. 1632; amended November 2, 1979, effective November 3, 1979, 9 Pa.B. 3652; amended December 28, 1979, effective December 29, 1979, 9 Pa.B. 4273; republished and compiled August 1, 1980, effective August 2, 1980, 10 Pa.B. 3199; amended August 22, 1986, effective August 23, 1986, 16 Pa.B. 3119; readopted December 4, 1987, effective December 5, 1987, 17 Pa.B. 5051; amended February 17, 1989, effective February 18, 1989, 19 Pa.B. 640; amended August 9, 1996, effective August 10, 1996, 26 Pa.B. 3833. Immediately preceding text appears at serial pages (218221) to (218224).

### Subchapter E. STOPWATCHES

Sec.

- 105.71. Approved stopwatches.
- 105.72. Equipment approval procedure.
- 105.73. Appointment of stopwatch testing stations.
- 105.74. Required equipment.
- 105.75. Manner of testing.
- 105.76. [Reserved].

**§ 105.71. Approved stopwatches.**

The following types of stopwatches are approved by the Department for use in timing the rate of speed of vehicles:

(1) *Mechanical stopwatches.* A mechanical stopwatch shall comply with the following standards:

(i) The face shall be fully graduated, with minimum graduations of 1/5 second.

(ii) The stopwatch shall be accurate to the equivalent of plus or minus 15 seconds per 24-hour period.

(2) *Electronic stopwatches.* An electronic stopwatch shall comply with the following standards:

(i) The common crystal frequency shall be 32,768 Hz with a measured frequency within plus or minus 3 Hz, or approximately .01% of the standard frequency.

(ii) The stopwatch shall be accurate to the equivalent of plus or minus 9 seconds per 24-hour period.

**Source**

The provisions of this § 105.71 adopted August 26, 1977, effective August 27, 1977, 7 Pa.B. 2422; amended August 18, 1978, effective August 19, 1978, 8 Pa.B. 2311; amended October 27, 1978, effective October 28, 1978, 8 Pa.B. 2918; republished and compiled August 1, 1980, effective August 2, 1980, 10 Pa.B. 3199; amended November 19, 1982, effective November 20, 1982, 12 Pa.B. 3983; readopted December 4, 1987, effective December 5, 1987, 17 Pa.B. 5051. Immediately preceding text appears at serial pages (111322) to (111323).

**Cross References**

This section cited in 67 Pa. Code § 105.72 (relating to equipment approval procedure); and 67 Pa. Code § 105.94 (relating to required equipment).

**§ 105.72. Equipment approval procedure.**

To obtain approval of a type of stopwatch, a laboratory report indicating that the type of stopwatch has been tested in accordance with this subchapter and meets the standards in § 105.71 (relating to approved stopwatches) shall be submitted to the Bureau of Motor Vehicles, Vehicle Control Division, Post Office Box 8697, Harrisburg, Pennsylvania 17105.

**Source**

The provisions of this § 105.72 adopted August 26, 1977, effective August 27, 1977, 7 Pa.B. 2422; amended August 18, 1978, effective August 19, 1978, 8 Pa.B. 2311; amended October 27, 1978, effective October 28, 1978, 8 Pa.B. 2918; republished and compiled August 1, 1980, effective August 2, 1980, 10 Pa.B. 3199; amended November 19, 1982, effective November 20, 1982, 12 Pa.B. 3983; readopted December 4, 1987, effective December 5, 1987, 17 Pa.B. 5051; amended February 17, 1989, effective February 18, 1989, 19 Pa.B. 640. Immediately preceding text appears at serial page (122766).

**§ 105.73. Appointment of stopwatch testing stations.**

A facility capable of testing the accuracy of a stopwatch and capable of making adjustments to assure the accuracy of a stopwatch may, upon application to the Bureau, be appointed as a stopwatch testing station.

**Source**

The provisions of this § 105.73 adopted August 26, 1977, effective August 27, 1977, 7 Pa.B. 2422; amended August 18, 1978, effective August 19, 1978, 8 Pa.B. 2311; amended October 27, 1978, effective October 28, 1978, 8 Pa.B. 2918; republished and compiled August 1, 1980, effective August 2, 1980, 10 Pa.B. 3199; amended November 19, 1982, effective November 20, 1982, 12 Pa.B. 3983; readopted December 4, 1987, effective December 5, 1987, 17 Pa.B. 5051. Immediately preceding text appears at serial page (111323).

**§ 105.74. Required equipment.**

(a) Stopwatch testing stations appointed to test mechanical stopwatches shall have at least one "Watch Master," vibrograf MU 700, or similar device.

(b) Stopwatch testing stations appointed to test electronic stopwatches shall have at least one digital counter of at least 1 part in  $10^6$  accuracy or vibrograf models MU700 or M80. The counter accuracy shall be traceable to the National Bureau of Standards.

**Source**

The provisions of this § 105.74 adopted August 26, 1977, effective August 27, 1977, 7 Pa.B. 2422; amended August 18, 1978, effective August 19, 1978, 8 Pa.B. 2311; amended October 27, 1978, effective October 28, 1978, 8 Pa.B. 2918; republished and compiled August 1, 1980, effective August 2, 1980, 10 Pa.B. 3199; amended November 19, 1982, effective November 20, 1982, 12 Pa.B. 3983; readopted December 4, 1987, effective December 5, 1987, 17 Pa.B. 5051. Immediately preceding text appears at serial page (111323).

**§ 105.75. Manner of testing.**

(a) *Test.*

(1) A mechanical stopwatch shall be tested with a "Watch Master" or similar device.

(2) An electronic stopwatch shall be tested by measuring the frequency of crystal between the common terminal at the base of the battery and the test point or output terminal on the crystal, with a digital counter of at least 1 part in  $10^6$  accuracy. The counter accuracy shall be traceable to the National Bureau of Standards. *Note:* Plus or minus 1 Hz is plus or minus 3 seconds in 24 hours; plus or minus 2 Hz is plus or minus 6 seconds in 24 hours; plus or minus 3 Hz is plus or minus 9 seconds in 24 hours.

(b) *Forms.* Upon determining that a stopwatch is accurate, a stopwatch testing station shall issue a certificate of accuracy on a form provided by the Department. The certificate shall contain the date of the test and the signature of the person who conducted the test. The certificate shall be kept on file for at least 2

years. A duplicate copy, executed and signed in the same manner as the original, has the same force and effect as the original.

**Source**

The provisions of this § 105.75 adopted August 26, 1977, effective August 27, 1977, 7 Pa.B. 2422; amended August 18, 1978, effective August 19, 1978, 8 Pa.B. 2311; amended October 27, 1978, effective October 28, 1978, 8 Pa.B. 2918; republished and compiled August 1, 1980, effective August 2, 1980, 10 Pa.B. 3199; amended November 19, 1982, effective November 20, 1982, 12 Pa.B. 3983; readopted December 4, 1987, effective December 5, 1987, 17 Pa.B. 5051; amended February 17, 1989, effective February 18, 1989, 19 Pa.B. 640. Immediately preceding text appears at serial page (122767).

**§ 105.76. [Reserved].**

**Source**

The provisions of this § 105.76 adopted October 27, 1978, effective October 28, 1978, 8 Pa.B. 2918; amended January 12, 1979, effective January 13, 1979, 9 Pa.B. 172; amended July 20, 1979, effective July 21, 1979, 9 Pa.B. 2401; amended September 28, 1979, effective September 29, 1979, 9 Pa.B. 3324; amended May 16, 1980, effective May 17, 1980, 10 Pa.B. 1980; amended May 30, 1980, effective May 31, 1980, 10 Pa.B. 2162; republished and compiled August 1, 1980, effective August 2, 1980, 10 Pa.B. 3199; amended January 15, 1982, effective January 16, 1982, 12 Pa.B. 299; amended November 19, 1982, effective November 20, 1982, 12 Pa.B. 3983; amended December 30, 1983, effective December 31, 1983, 13 Pa.B. 4021; reserved March 30, 1984, effective March 31, 1984, 14 Pa.B. 1089. Immediately preceding text appears at serial pages (85977) to (85978), (86615) to (86616) and (85979) to (85983).

**Subchapter F. ELECTRONIC DEVICES (NONRADAR) WHICH  
CALCULATE AVERAGE SPEED BETWEEN ANY TWO POINTS**

Sec.

105.91. [Reserved].

105.92. [Reserved].

105.92a. Application of subchapter.

105.93. Operation of maintenance and calibration stations.

105.94. Required equipment.

105.95. Manner of calibration and testing.

**Source**

The provisions of this Subchapter F adopted May 16, 1980, effective May 17, 1980, 10 Pa.B. 1980; amended August 22, 1986, effective August 23, 1986, 16 Pa.B. 3119, unless otherwise noted. Immediately preceding text appears at serial pages (87719) to (87720) and (71201) to (71203).

105-21

(218227) No. 262 Sep. 96

**§ 105.91. [Reserved].****Source**

The provisions of this § 105.91 adopted May 16, 1980, effective May 17, 1980, 10 Pa.B. 1980; republished and compiled August 1, 1980, effective August 2, 1980, 10 Pa.B. 3199; reserved March 30, 1984, effective March 31, 1984, 14 Pa.B. 1089. Immediately preceding text appears at serial page (83725).

**§ 105.92. [Reserved].****Source**

The provisions of this § 105.92 adopted May 16, 1980, effective May 17, 1980, 10 Pa.B. 1980; republished and compiled August 1, 1980, effective August 2, 1980, 10 Pa.B. 3199; amended October 17, 1980, effective October 18, 1980, 10 Pa.B. 4101; amended December 19, 1980, effective December 20, 1980, 10 Pa.B. 4732; amended January 15, 1982, effective January 16, 1982, 12 Pa.B. 299; amended May 28, 1982, effective May 29, 1982, 12 Pa.B. 1698; amended November 12, 1982, effective November 13, 1982, 12 Pa.B. 3946; amended November 19, 1982, effective November 20, 1982, 12 Pa.B. 3983; amended September 2, 1983, effective September 3, 1983, 13 Pa.B. 2704; amended December 30, 1983, effective December 31, 1983, 13 Pa.B. 4021; reserved March 30, 1984, effective March 31, 1984, 14 Pa.B. 1089. Immediately preceding text appears at serial page (83725) to (83726).

**§ 105.92a. Application of subchapter.**

This subchapter governs the calibration and testing of electronic devices—nonradar—which calculate the average speed between any two points, for use by a police officer, under 75 Pa.C.S. § 3368(c)(3) (relating to speed timing devices).

**Source**

The provisions of this § 105.92a adopted August 22, 1986, effective August 23, 1986, 16 Pa.B. 3119; readopted December 4, 1987, effective December 5, 1987, 17 Pa.B. 5051; amended February 17, 1989, effective February 18, 1989, 19 Pa.B. 640. Immediately preceding text appears at serial page (122768).

**§ 105.93. Operation of maintenance and calibration stations.**

(a) *Maintenance and calibration.* Maintenance and calibration of electronic devices governed by this subchapter shall be provided, as necessary, upon request by State or local police.

(b) *Hours.* Stations for the maintenance and calibration of electronic devices shall be operated during a regular work week, Monday through Friday during the hours of 8 a.m. to 5 p.m.

(c) *Personnel.* A station for the maintenance and calibration of electronic devices shall employ on a full-time basis:

- (1) An electrical engineer or metrologist.
- (2) An associate engineer, associate metrologist or technician.

(d) *Certification of accuracy.* Either the electrical engineer, associate engineer, metrologist, associate metrologist or technician shall be present at the time that the testing is conducted. The certification that the electronic speed-timing

device has been tested and found to be accurate creates a presumption that the requirements of this subsection have been fulfilled.

(e) *Malfunctioning devices.* Malfunctioning electronic devices shall be returned to the manufacturer or to a service center approved by the manufacturer and tagged with the date tested, the serial number of the device and a notation of the general condition of the device.

(f) *Damage to or loss of device.* The station for the maintenance and calibration of electronic devices is responsible for damages or losses of the devices while they are being serviced or calibrated.

(g) *Location.* Electronic testing and repair shall take place at an approved electronic testing station, except that, upon approval of the Department, an electronic testing station may operate mobile test units of a type approved by the Department.

#### Source

The provisions of this § 105.93 adopted May 16, 1980, effective May 17, 1980, 10 Pa.B. 1980; republished and compiled August 1, 1980, effective August 2, 1980, 10 Pa.B. 3199; amended August 22, 1986, effective August 23, 1986, 16 Pa.B. 3119; readopted December 4, 1987, effective December 5, 1987, 17 Pa.B. 5051; amended February 17, 1989, effective February 18, 1989, 19 Pa.B. 640. Immediately preceding text appears at serial pages (122768) to (122769).

### § 105.94. Required equipment.

The following equipment is required for the operation of a station for the maintenance and calibration of electronic devices governed by this subchapter:

- (1) Tape measure capable of measuring distances of at least 1/4 mile.
- (2) Stopwatch approved under § 105.71 (relating to approved stopwatches).
- (3) Handheld calculator.

#### Source

The provisions of this § 105.94 adopted May 16, 1980, effective May 17, 1980, 10 Pa.B. 1980; republished and compiled August 1, 1980, effective August 2, 1980, 10 Pa.B. 3199; amended August 22, 1986, effective August 23, 1986, 16 Pa.B. 3119; readopted December 4, 1987, effective December 5, 1987, 17 Pa.B. 5051. Immediately preceding text appears at serial page (111325).

### § 105.95. Manner of calibration and testing.

(a) *Method.* An electronic device governed by this subchapter shall be calibrated and tested as follows:

- (1) Establish a measured 1/4-mile course with a tape, preferably on a relatively flat and straight roadway.
- (2) Run through this 1/4 mile with both the time and distance switch on at the beginning and the turn switch off at the end. Push the distance recall but-

ton. Distance will be displayed to the nearest ten thousandths of a mile—that is, .2500. If calibration is correct, reading should be within + or – 1%, or + or – .0025 mile.

(3) If calibration is out, recalibrate according to the instructions of the manufacturer.

(4) A course other than a 1/4-mile course can be used, but not less than 1/10 mile.

(5) Run through the measured course of 1/4 mile with both the time and distance switch on at the beginning and off at the end. Push the distance recall button and record the actual distance in the unit—that is, .2504.

(6) There is now an accurate fixed distance in the machine that is within the + or – 1% tolerance. With the aid of a stopwatch, check the accuracy for the vehicular speed desired by turning the red time switch on the speed will be displayed. This can be compared with the calculated speed described in paragraph (7).

(7) Average speed is distance divided by time. With the use of a handheld calculator, divide the distance by time and multiply by 3,600 to convert seconds into hours. Use the time recall button to get the time in seconds. Also use the actual course measured distance—that is, .2500 miles—in the calculations.

*Example:*

Do not touch the distance switch after running the 1/4 mile course. By pushing the recall button, it should indicate a distance of .2504. Enter a nominal 15 seconds with the time switch which is checked with the time recall. It actually will be 15.10 and a speed display of 59.7 mph. Now calculate the average speed using actual time and actual distance.

$$\text{SPEED} = \frac{.2500 \text{ miles}}{15.10 \text{ sec.}} \times \frac{3600 \text{ sec.}}{\text{hour}} = 59.6 \text{ mph}$$

This compares very favorably with the speed reading of the unit 59.7 (.17%). This procedure should be used for other speeds by varying the time input to the unit.

(8) High speed running checks may be made checking against the calibrated speedometer of the vehicle. To do this, drive the vehicle at a specific speed. Turn both time and distance switches on. Wait 5 seconds and turn both switches off. The speed will be displayed.

(b) *Maintenance work-order.* A maintenance work-order containing the following information shall be completed and accompany the electronic device:

- (1) The serial number of the device.
- (2) The work performed and the date of the work.
- (3) The original complaint.
- (4) The actual work performed.
- (5) The amount of time taken in repair of the unit.
- (6) The stock numbers of the equipment replaced.



(c) *Calibration forms.* Certificates of accuracy, provided by the Department, shall be filed for electronic devices calibrated and tested as follows:

- (1) The original and a duplicate shall accompany the electronic device.
- (2) One duplicate copy shall be retained by the maintenance and calibration station for at least 2 years.
- (3) A duplicate copy, executed and signed in the same manner as the original, has the same force and effect as the original.

(d) *Testing forms.* Technical data forms, provided by the Department, shall be filed for electronic devices tested as follows:

- (1) One original shall accompany the electronic device.
- (2) Two duplicate copies shall be retained by the maintenance and calibration station for at least 2 years.
- (3) A duplicate copy, executed and signed in the same manner as the original, has the same force and effect as the original.

(e) *Equipment, timing strips and other devices.* The calibration and testing of equipment, timing strips and other devices actually used with a particular electronic device—nonradar—shall be performed under the specifications provided by the manufacturer of an approved device using equipment specified by the manufacturer or equivalent substitute equipment.

#### Source

The provisions of this § 105.95 adopted May 16, 1980, effective May 17, 1980, 10 Pa.B. 1980; republished and compiled August 1, 1980, effective August 2, 1980, 10 Pa.B. 3199; corrected May 28, 1982, effective May 9, 1981, 12 Pa.B. 1697; amended August 22, 1986, effective August 23, 1986, 16 Pa.B. 3119; readopted December 4, 1987, effective December 5, 1987, 17 Pa.B. 5051; amended February 17, 1989, effective February 18, 1989, 19 Pa.B. 640. Immediately preceding text appears at serial pages (122769) to (122771).

#### Notes of Decisions

Trial court did not err in admitting into evidence a VASCAR-PLUS unit speed-reading taken over a distance of less than the distance specified for calibration by the Department of Transportation because the legislature did not intend to establish a minimum distance requirement for the use of VASCAR PLUS unit, instead the legislature intended to establish a method to calibrate and test an electronic unit. *Commonwealth v. Vishneski*, 552 A.2d 297 (Pa. Super. 1989).

APPENDIX A

**NOTE:**

Chambers construction consists of 1/2" plywood. All interior sides lined with aluminum foil and then covered with ECCOSORB AN 73 (3/8" thick) or equivalent.

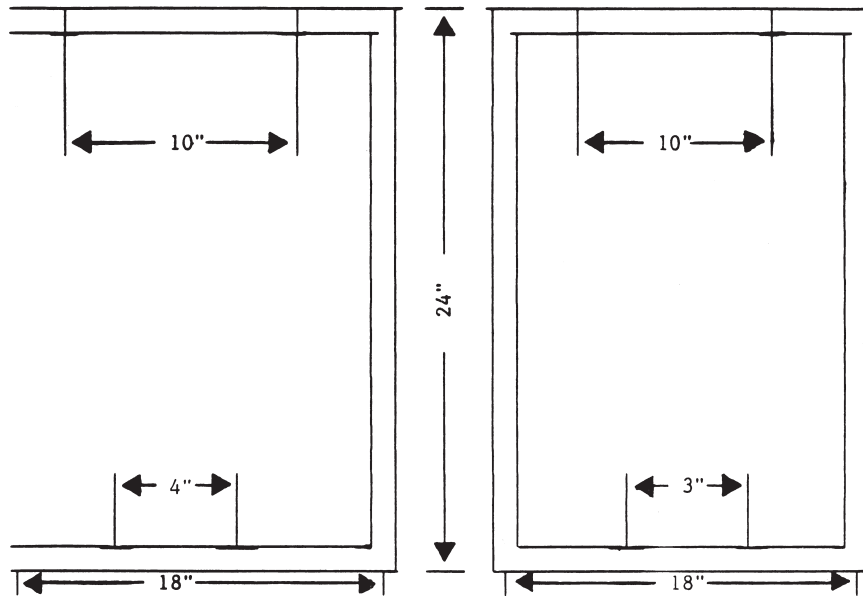
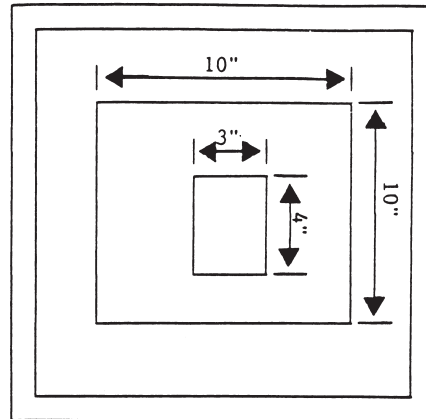

FIGURE 1

105-26

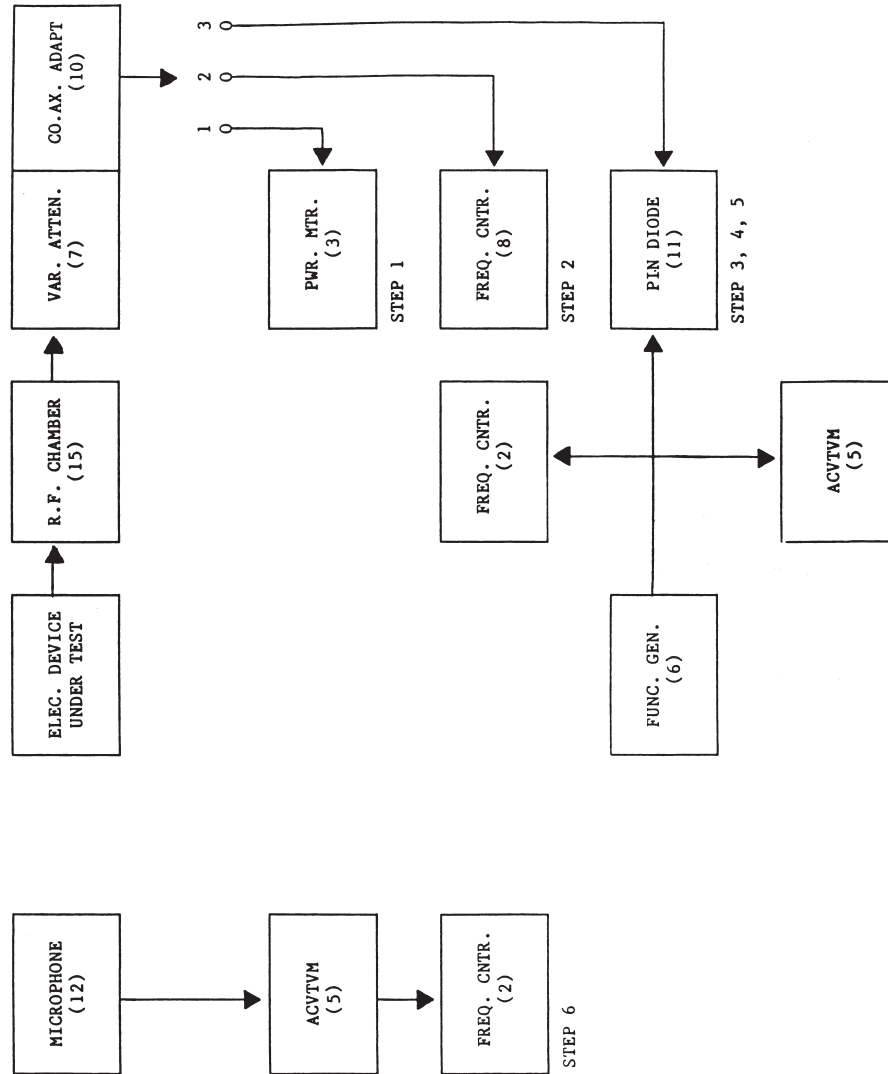

FIGURE 2

105-27

**USM 207 Universal Counter  
in B C Time Mode**

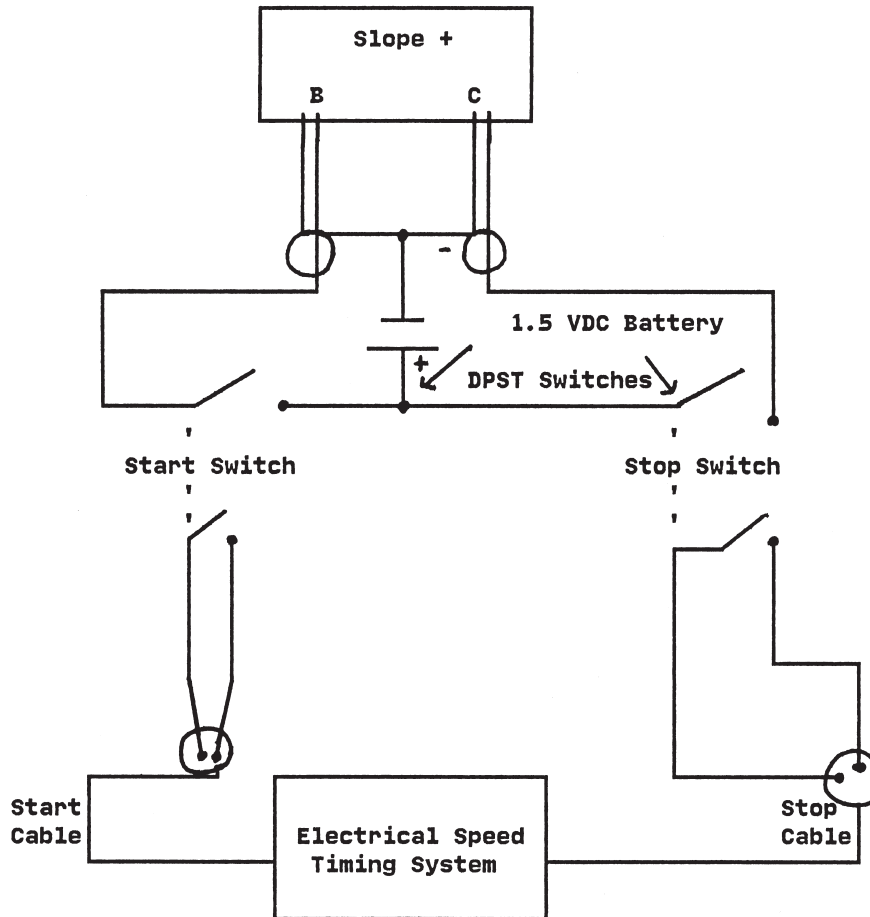

FIGURE 3  
Electrical Speed-Timing System  
Equipment Setup

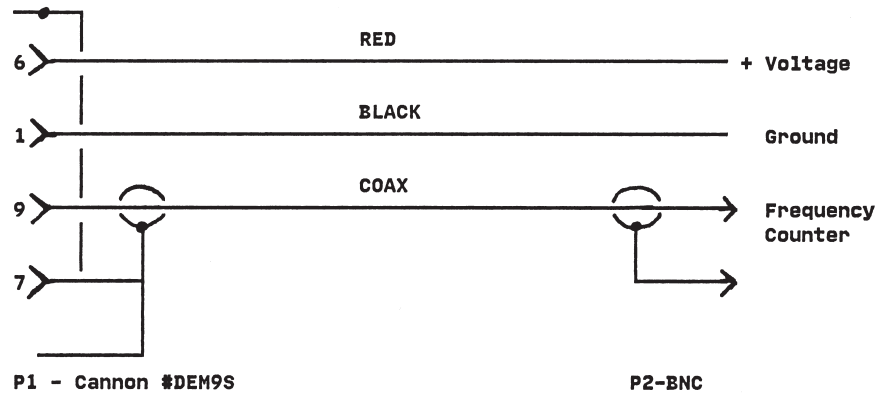

FIGURE 4  
Model TK 100, ESP/Infrared  
Test Cable Wiring Diagram

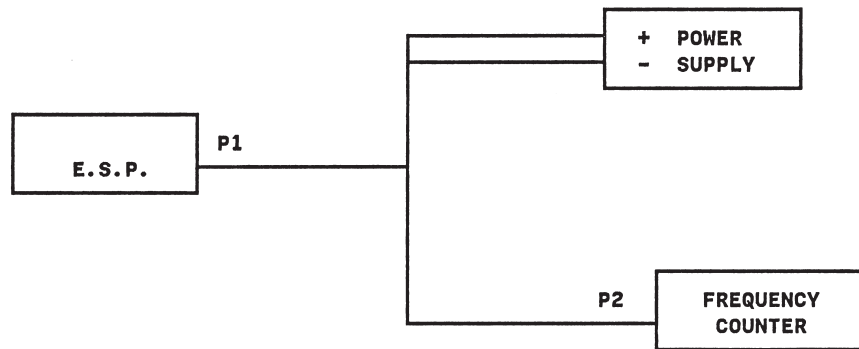

FIGURE 5  
Model TK 100, ESP/Infrared  
Test Setup

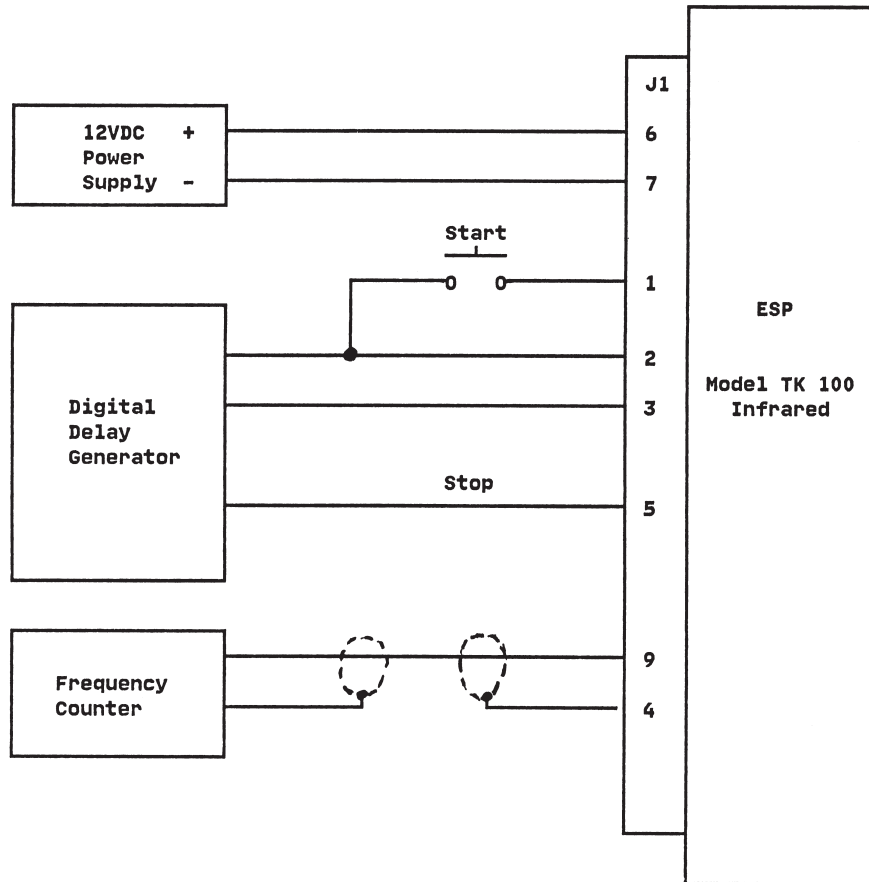

FIGURE 6  
Model TK 100, ESP/Infrared  
Interconnection Diagram

DEPARTMENT OF TRANSPORTATION

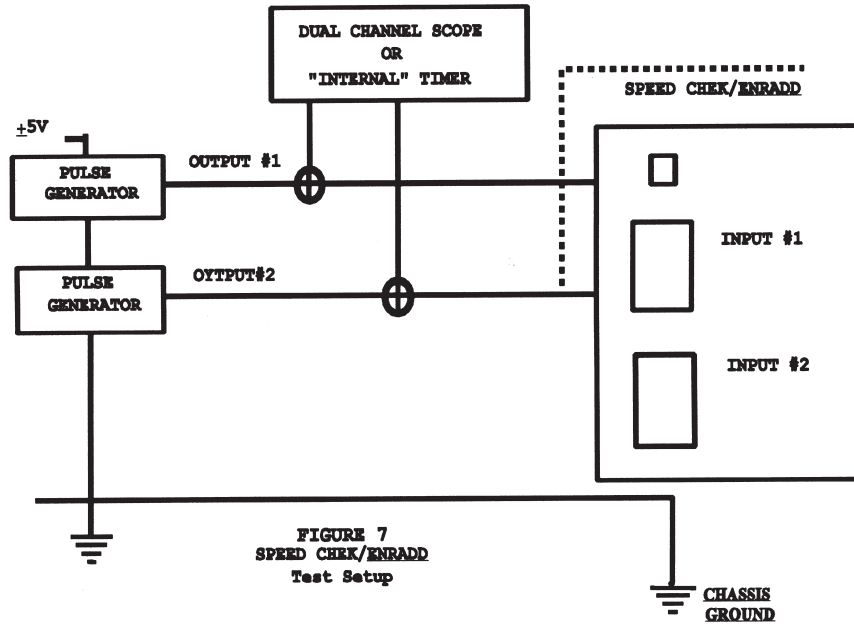

FIGURE 7  
SPEED CHEK/ENRADD  
Test Setup

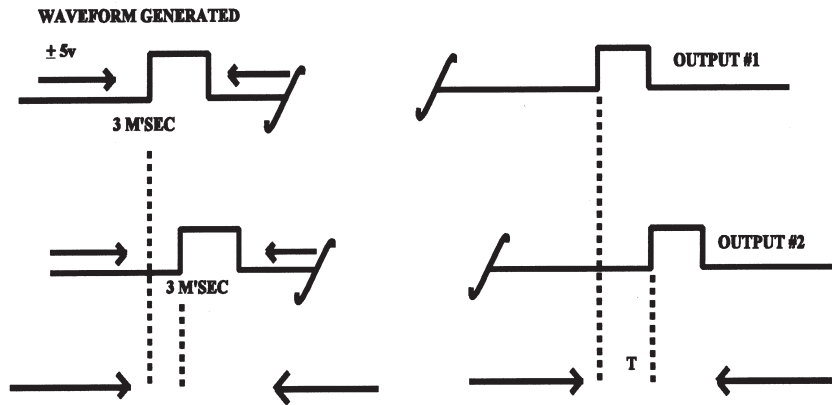

FIGURE 8  
SPEED CHEK/ENRADD  
Interconnection Diagram

**Source**

The provisions of this Appendix A amended August 9, 1996, effective August 10, 1996, 26 Pa.B. 3833. Immediately preceding text appears at serial pages (218237) to (218238).

**Cross References**

This appendix cited in 67 Pa. Code § 105.15 (relating to calibration and testing procedure); and 67 Pa. Code § 105.56 (relating to manner of calibration and testing).

[Next page is 107-1.]

105-32