

CHAPTER 159. NEW PNEUMATIC TIRES

Sec.	
159.1.	Scope.
159.2.	Application.
159.3.	Definitions.
159.4.	Requirements.
159.5.	Test procedures.
159.6.	Nonconforming tires.

Authority

The provisions of this Chapter 159 issued under the Vehicle Code, 75 Pa.C.S. §§ 4103 and 4525, unless otherwise noted.

Source

The provisions of this Chapter 159 adopted September 30, 1977, effective October 1, 1977, 7 Pa.B. 2808, unless otherwise noted.

Cross References

This chapter cited in 67 Pa. Code § 175.65 (relating to tires and wheels); 67 Pa. Code § 175.95 (relating to tires and wheels); 67 Pa. Code § 175.124 (relating to tires and wheels); 67 Pa. Code § 175.145 (relating to tires and wheels); and 67 Pa. Code § 175.174 (relating to tires and wheels).

§ 159.1. Scope.

This chapter specifies tire dimensions and laboratory test requirements for bead unseating resistance, strength, endurance, and high speed performance; defines tire load ratings; and specifies labeling requirements for passenger car tires.

§ 159.2. Application.

This chapter shall apply to new pneumatic tires for use on passenger cars manufactured after 1948. However, it shall not apply to any tire which has been altered so as to render impossible its use, or its repair for use, as motor vehicle equipment.

§ 159.3. Definitions.

The following words and terms, when used in this chapter, have the following meanings, unless the context clearly indicates otherwise:

Bead—That part of the tire made of steel wires, wrapped or reinforced by ply cords, that is shaped to fit the rim.

Bead separation—A breakdown of bond between components in the bead area.

Bias ply tire—A pneumatic tire in which the ply cords that extend to the beads are laid at alternate angles substantially less than 90° to the centerline of the tread.

Carcass—The tire structure, except tread and sidewall rubber.

Chunking—The breaking away of pieces of the tread or sidewall.

Cord—The strands forming the plies in the tire.

Cord separation—Cords parting away from adjacent rubber compounds.

Cracking—Any parting within the tread, sidewall or innerliner of the tire extending to cord material.

Groove—The space between two adjacent tread ribs.

Innerliner—The layers forming the inside surface of a tubeless tire that contains the inflating medium within the tire.

Innerliner separation—The parting of the innerliner from cord material in the carcass.

Load rating—The maximum load a tire is rated to carry for a given inflation pressure.

Maximum load rating—The load rating at the maximum permissible inflation pressure for that tire.

Maximum permissible inflation pressure—The maximum cold inflation pressure to which a tire may be inflated.

Open splice—Any parting at any junction of tread, sidewall or innerliner that extends to cord material.

Overall width—The linear distance between the exteriors of the sidewalls of an inflated tire, including elevations due to labeling, decorations or protective bands or ribs.

Ply—A layer of rubber-coated parallel cords.

Ply separation—A parting of rubber compound between adjacent plies.

Pneumatic tire—A mechanical device made of rubber, chemicals, fabric and steel or other materials, which, when mounted on an automotive wheel, provides the traction and contains the gas or fluid that sustains the load.

Radial ply tire—A pneumatic tire in which the ply cords which extend to the beads are laid at substantially 90° to the centerline of the tread.

Rim—A metal support for a tire or a tire and tube assembly upon which the tire beads are seated.

Section width—The linear distance between the exteriors of the sidewalls of an inflated tire, excluding elevations due to labeling, decoration, or protective bands.

Sidewall—That portion of a tire between the tread and the bead.

Sidewall separation—The parting of the rubber compound from the cord material in the sidewall.

Size factor—The sum of the section width and the outer diameter of a tire determined on the test rim.

Test rim—With reference to a tire to be tested, any rim that is listed as appropriate for use with that tire in accordance with § 159.4(d) (relating to requirements). For purposes of this chapter and section 571.110, each rim listing shall include dimensional specifications and a diagram of the rim.

Tread—That portion of a tire that comes into contact with the road.

Tread rib—A tread section running circumferentially around a tire.

Tread separation—Pulling away of the tread from the tire carcass.

Cross References

This section cited in 67 Pa. Code § 159.4 (relating to requirements).

§ 159.4. Requirements.

(a) *Size and construction.* Each tire shall be designed to fit each rim specified for its size designation in each reference cited in the definition of test rim in § 159.3 (relating to definitions).

(b) *Performance requirements.* Performance requirements shall be as follows:

(1) *General.* Each tire shall conform to each of the following:

(i) It shall meet the requirements specified in paragraph (2) for its tire size designation, type and maximum permissible inflation pressure.

(ii) Its maximum permissible inflation pressure shall be either 32, 36, 40, or 60 p.s.i., or 240, 280 or 300 KPa.

(iii) Its load rating shall be that specified in Table I of Appendix A of this chapter for its size designation, type and each appropriate inflation pressure.

(iv) If manufactured on or after August 1, 1968, it shall incorporate a tread wear indicator that will provide a visual indication that the tire has worn to a tread depth of 1/16 inch.

(v) It shall, before being subjected to either the endurance test procedure specified in § 159.5(d) (relating to test procedures) or the high speed performance procedure specified in § 159.5(e), exhibit no visual evidence of tread, sidewall, ply, cord, innerliner, or bead separation, chunking, broken cords, cracking or open splices.

(vi) It shall meet the requirements of paragraph (2)(v) and (2)(vi) when tested on a test wheel described in § 159.5(d)(2)(i) (relating to test procedures), either alone or simultaneously with up to five other tires.

(2) *Test requirements.* Test requirements shall be as follows:

(i) *Test sample.* For each test sample the following shall be used:

(A) One tire for physical dimensions, resistance to bead unseating, and strength, in sequence.

(B) Another tire for tire endurance.

(C) A third tire for high speed performance.

(ii) *Physical dimensions.* Each tire, when measured in accordance with § 159.5(a) shall conform with each of the following:

(A) Its actual section width and overall width shall not exceed by more than 7.0% the section width specified in Table I of Appendix A for its size designation and type.

(B) Its size factor shall be at least as large as that specified in Table I of Appendix A for its size designation and type.

(iii) *Tubeless tire resistance to bead unseating.* When tested in accordance with § 159.5(b), the applied force required to unseat the tire bead at the point of contact is less than:

(A) 1,500 pounds for tires with a designated section width of less than 6 inches.

(B) 2,000 pounds for tires with a designated section width of 6 inches or more but less than 8 inches.

(C) 2,500 pounds for tires with a designated section width of 8 inches or more, using the section width specified in Table I of Appendix A for the applicable tire size designation and type.

(iv) *Tire strength.* Each tire shall meet the requirements for minimum breaking energy specified in Table II of Appendix A when tested in accordance with § 159.5(c).

(v) *Tire endurance.* When the tire has been subjected to the laboratory endurance test specified in § 159.5(d) using a test rim that undergoes no permanent deformation and allows no loss of air through the portion that it comprises of the tire-rim pressure chamber:

(A) There shall be no visual evidence of tread, sidewall, ply, cord, innerliner, or bead separation, chunking, broken cords, cracking or open splices.

(B) The tire pressure at the end of the test shall be not less than the initial pressures specified in § 159.5(d)(1)(i).

(vi) *High speed performance.* When the tire has been subjected to the laboratory high speed performance test specified in § 159.5(e), using a test rim that undergoes no permanent deformation and allows no loss of air through the portion that it comprises of the tire rim pressure chamber, the tire shall meet the requirements set forth in subparagraph (v)(A) and (B).

(c) *Labeling requirements.* Labeling requirements shall be as follows:

(1) Except as provided in paragraphs (2) and (3), each tire shall have permanently molded into or onto both sidewalls, in letters and numerals not less than 0.078 inches high, the information shown in subparagraphs (i) through (vii). On at least one sidewall, the information shall be positioned in an area between the maximum section width and bead of the tire. However, in no case shall the information be positioned on the tire so that it is obstructed by the flange of any rim designed for use with that tire under the provisions of this chapter and Standard No. 571.110.

(i) One size designation, except that equivalent inch and metric size designations may be used.

(ii) Maximum permissible inflation pressure.

(iii) Maximum load rating.

(iv) The generic name of each cord material used in the plies, both sidewall and tread area, of the tire.

- (v) Actual number of plies in the sidewall, and the actual number of plies in the tread area, if different.
 - (vi) The words “tubeless” or “tube type” as applicable.
 - (vii) The word “radial” if the tire is a radial ply tire.
- (2) Each tire shall be labeled with the symbol “DOT” in the manner specified in 49 CFR Part 574, which shall constitute a certification that the tire conforms to applicable Federal motor vehicle safety standards.
- (3) Each tire shall be labeled with the name of the manufacturer, or brand name and number assigned to manufacturer in the manner specified in 49 CFR Part 574.
- (4) Each tire manufactured between March 1, 1971, and May 22, 1971, shall either:
- (i) Comply with section 4.3(d)(2) and 4.3(i), as effective until May 22, 1971.
 - (ii) Be labeled with the tire identification number required by 49 CFR 574.5 and comply with paragraphs (2) and (3) as effective on and after May 22, 1971.
- (d) *Tire and rim matching information.* Matching information requirements shall be as follows:
- (1) Each manufacturer of tires shall ensure that a listing of the rims that may be used with each tire that he produces is provided to the public. A listing compiled in accordance with subparagraph (i) need not include dimensional specifications or diagram of a rim if the dimensional specifications and diagram of the rim are contained in each listing published in accordance with subparagraph (ii). The listing shall be in one of the following forms:
- (i) Listed by manufacturer name or brand name in a document furnished to dealers of the manufacturer’s tires, to any person upon request, and in duplicate to: Tire Division, National Highway Traffic Safety Administration, 400 Seventh Street S.W., Washington D.C. 20590.
 - (ii) Contained in publications current at the date of manufacture of the tire or any later date of at least one of the following organizations:
 - (A) The Tire and Rim Association.
 - (B) The European Tyre and Rim Technical Organisation.
 - (C) Japanese Industrial Standards.
 - (D) Deutsche Industrie Norm.
 - (E) The Society of Motor Manufacturers and Traders, Ltd.
 - (F) British Standards Institution.
 - (G) Scandinavian Tire and Rim Organisation.
- (2) Information contained in any publication specified in paragraph (1)(ii) of this subsection which lists general categories of tires and rims by size designation, type of construction or intended use, shall be considered to be information of the manufacturer under paragraph (1) for the listed tires and rims,

unless the publication itself or specific information provided according to paragraph (1)(i) indicates otherwise.

Source

The provisions of this § 159.4 amended January 26, 1979, effective January 27, 1979, 9 Pa.B. 346.

Cross References

This section cited in 67 Pa. Code § 159.3 (relating to definitions); and 67 Pa. Code § 159.5 (relating to test procedures).

§ 159.5. Test procedures.

(a) *Physical dimensions.* Tire physical dimensions shall be determined under uniform ambient conditions as follows:

(1) Mount the tire on a test rim having the test rim width specified in Appendix A of this chapter for that tire size designation and inflate it to the applicable pressure specified in Table III of Appendix A.

(2) Condition it at ambient room temperature for at least 24 hours.

(3) Readjust pressure to that specified in paragraph (1).

(4) Caliper the section width and overall width at six points approximately equally spaced around the tire circumference.

(5) Record the average of these measurements as the section width and overall width, respectively.

(6) Determine tire outer diameter by measuring the maximum circumference of the tire and dividing this dimension by pi (3.14).

(b) *Tubeless tire bead unseating resistance.* Bead unseating resistance shall be tested as follows:

(1) *Preparation of tire-wheel assembly.* The tire-wheel assembly shall be prepared as follows:

(i) Wash the tire, dry it at the beads, and mount it without lubrication or adhesives on a clean, painted test rim.

(ii) Inflate it to the applicable pressure specified in Table III of Appendix A of this chapter at ambient room temperature.

(iii) Mount the wheel and tire in the fixture shown in Figure 1 of this section, and force the standard block shown in Figure 2 of this section, against the tire sidewall as required by the geometry of the fixture.

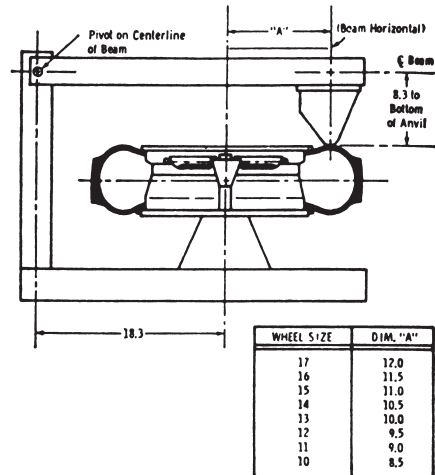

Bead Unsealing Fixture Dimensions in Inches

Figure 1

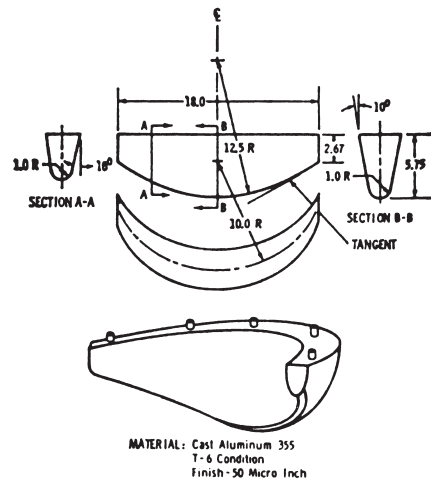

Diagram of Bead Unsealing Block Dimensions in Inches

Figure 2

(2) *Test procedure.* The test procedure shall be as follows:

(i) Apply a load through the block to the tire outer sidewall at the distance specified in Figure 1 of this section for the applicable wheel size at a rate of two inches per minute, with the load arm substantially parallel to the tire and rim assembly at the time of engagement.

(ii) Increase the load until the bead unseats or the applicable value specified in § 159.4(b)(2)(iii) (relating to requirements) is reached.

(iii) Repeat the test at least four places equally spaced around the tire circumference.

(c) *Tire strength.* Tire strength shall be tested as follows:

(1) *Preparation of tire.* The tire shall be prepared as follows:

(i) mount the tire on a test rim and inflate it to the applicable pressure specified in Table III of Appendix A of this chapter;

(ii) condition it at room temperature for at least three hours; and

(iii) readjust its pressure to that specified in subparagraph (i).

(2) *Test procedure.* The test procedure shall be as follows:

(i) Force a 3/4-inch diameter cylindrical steel plunger with a hemispherical end perpendicularly into the tread rib as near to the centerline as possible, avoiding penetration into the tread groove, at the rate of two inches per minute.

(ii) Record the force and penetration at five test points equally spaced around the circumference of the tire. If the tire fails to break before the plunger is stopped by reaching the rim, record the force and penetration as the rim is reached and use these values in subparagraph (iii).

(iii) Compute the breaking energy for each test point by means of the following formula:

$$W = \frac{F \times P}{2}$$

W =Energy, inch-pounds;

F =Force, pounds; and

P =Penetration, inches.

(iv) Determine the breaking energy value for the tire by computing the average of the five values obtained in accordance with subparagraph (iii) of this paragraph.

(d) *Tire endurance.* Endurance shall be tested as follows:

(1) *Preparation of tire.* The tire shall be prepared as follows:

(i) Mount a new tire on a test rim and inflate it to the applicable pressure specified in Table III of Appendix A.

(ii) Condition the tire assembly to 100°F plus or minus 5°F for at least three hours.

(iii) Readjust tire pressure to that specified in subparagraph (i) immediately before testing.

(2) *Test procedure.* The test procedure shall be as follows:

(i) Mount the tire and wheel assembly on a test axle and press it against a flat-faced steel test wheel 67.23 inches in diameter and at least as wide as the section width of the tire to be tested or an approved equivalent test wheel, with the applicable test load specified in Table I of Appendix A for the size designation, type, and maximum permissible inflation pressure of the tire.

(ii) During the test, the air surrounding the test area shall be 100°F plus or minus 5°F.

(iii) Conduct the test at 50 miles per hour in accordance with the following schedule without pressure adjustment or other interruptions:

Loads for —

<i>Maximum permissible inflation pressure</i>	<i>4 hours</i>	<i>6 hours</i> <i>Loads from table I (listed in specified psi or KPa column)</i>	<i>24 hours</i>
32 psi	24	28	32
36 psi	28	32	36
40 psi	32	36	40
240 KPa	180	220	240
280 KPa	220	260	280
300 KPa	180	220	240
		<i>Load as specified percentage of maximum load rating marked on tire sidewall</i>	
60 psi	85	92	100

(iv) Immediately after running the tire the required time, measure its inflation pressure. Allow the tire to cool for one hour. Then deflate the tire, remove it from the test rim, and inspect it for the conditions specified in § 159.4(b)(2)(v)(A) (relating to requirements).

(e) *High speed performance.* High speed performance shall be tested as follows:

(1) After preparing the tire in accordance with subsection (d)(1), mount the tire and wheel assembly in accordance with subsection (d)(2)(i) and press it against the test wheel with the load specified in Table I of Appendix A for the size designation of the tire and the applicable pressure specified in Column B of the following table:

<i>A</i> <i>Maximum permissible inflation pressure</i>	<i>B</i> <i>Load from Table I</i>
32 psi	24
36 psi	28
40 psi	32
240 KPa	180 KPa column.
280 KPa	220 KPa column.
300 KPa	180 KPa column.
	<i>Load as specified percentage of maximum load rating marked on tire sidewall</i>
60 psi	85

(2) Break in the tire by running it for two hours at 50 miles per hour.

(3) Allow to cool to 100°F plus or minus 5°F and readjust the inflation pressure to the applicable pressure specified in Table III of Appendix A of this chapter.

(4) Without readjusting inflation pressure, test at 75 miles per hour for 30 minutes, 80 miles per hour for 30 minutes, and 85 miles per hour for 30 minutes.

(5) Immediately after running the tire the required time, measure its inflation pressure. Allow the tire to cool for one hour. Then deflate the tire, remove it from the test rim, and inspect it for the conditions specified in § 159.4(b)(2)(v)(A).

Source

The provisions of this § 159.5 amended January 26, 1979, effective January 27, 1979, 9 Pa.B. 346.

Cross References

This section cited in 67 Pa. Code § 159.4 (relating to requirements).

§ 159.6. Nonconforming tires.

No tire of a type and size designation specified in Table I of Appendix A that is designed for use on passenger cars and manufactured on or after October 1, 1972, but does not conform to all the requirements of this standard, shall be sold, offered for sale, introduced or delivered for introduction in interstate commerce, or imported into the United States, for any purpose.

APPENDIX A

The following tables list tire sizes and tire constructions with proper load and inflation values. The tables group tires of related constructions and load-inflation values. Persons requesting the addition of new tire sizes to the tables or the addition of tables for new tire constructions may, when the additions requested are compatible with existent groupings, or when adequate justification for new tables exists, submit five copies of information and data supporting the request to the Secretary of Transportation, Attention: Motor Vehicle Programs, National Highway Traffic Safety Administration, U.S. Department of Transportation, Washington, D.C. 20590.

The information should contain the following:

- (1) The tire size designation, and a statement either that the tire is an addition to a category of tires listed in the tables or that it is in a new category for which a table has not been developed.
- (2) The tire dimensions, including aspect ratio, size factor, section width, overall width and test rim size.
- (3) The load-inflation schedule of the tire.
- (4) A statement as to whether the tire size designation and load-inflation schedule has been coordinated with the Tire and Rim Association, the European Tyre and Rim Technical Organisation, the society of Manufacturers and Traders Limited, the Japan Automobile Tire Manufacturers Association, the Deutsche Industrie Norm and the Scandinavian Tire and Rim Organisation.
- (5) Copies of test data sheets showing test conditions, results and conclusions obtained for individual tests specified in this chapter.
- (6) Justification for the additional tire sizes.

FEDERAL MOTOR VEHICLE SAFETY STANDARD NO. 109

TABLE I-A

TIRE LOAD RATINGS, TEST RIMS, MINIMUM SIZE FACTORS, AND SECTION WIDTHS FOR CONVENTIONAL AND LOW SECTION HEIGHT BIAS PLY TIRES

Tire size designation ¹	Maximum tire loads (pounds) at various cold inflation pressures (p.s.i.)											Test rim width (inches)	Minimum size factor	Section width ² (inches)	
	16	18	20	22	24	26	28	30	32	34	36				38
6.00-13	770	820	860	900	930	970	1010	1040	1080	1110	1140	1140	1140	29.37	6.00
6.50-13	890	930	980	1030	1080	1130	1180	1230	1270	1310	1360	1400	1440	30.75	6.60
7.00-13	980	1030	1080	1130	1180	1230	1270	1310	1360	1400	1440	1440	1440	31.88	7.10
6.00-14	840	900	960	1000	1050	1100	1150	1200	1250	1300	1350	1400	1450	30.64	6.10
6.45-14	860	910	960	1010	1060	1110	1160	1210	1260	1310	1360	1410	1460	30.92	6.60
6.50-14	880	930	980	1030	1080	1130	1170	1220	1270	1320	1370	1420	1470	31.75	6.60
6.95-14	950	1000	1050	1100	1140	1190	1230	1270	1310	1350	1390	1430	1470	31.96	7.00
7.00-14	1030	1100	1140	1190	1240	1290	1340	1390	1440	1490	1540	1590	1640	32.88	7.10
7.50-14	1040	1100	1160	1210	1260	1310	1360	1410	1460	1510	1560	1610	1660	32.92	7.30
7.75-14	1150	1210	1270	1330	1390	1440	1500	1550	1600	1650	1700	1750	1800	34.09	7.75
8.00-14	1240	1320	1380	1440	1500	1560	1620	1670	1730	1780	1830	1880	1930	35.17	8.10
8.25-14	1250	1310	1380	1440	1500	1560	1620	1670	1730	1780	1830	1880	1930	35.11	8.20
8.50-14	1330	1420	1480	1550	1610	1670	1740	1790	1850	1910	1960	2010	2060	35.91	8.35
8.55-14	1360	1430	1510	1580	1640	1710	1770	1830	1890	1950	2000	2050	2100	36.06	8.50
8.85-14	1430	1510	1580	1660	1730	1790	1860	1920	1990	2050	2100	2150	2200	36.82	8.95
9.00-14	1430	1510	1580	1660	1730	1790	1860	1920	1990	2050	2100	2150	2200	36.91	8.80
9.50-14	1540	1640	1700	1780	1850	1930	2000	2060	2130	2200	2260	2320	2380	37.74	9.05
6.00-15	890	940	980	1030	1070	1110	1150	1190	1230	1270	1310	1350	1390	31.64	6.10
6.50-15	980	1040	1080	1130	1180	1230	1270	1320	1360	1400	1440	1480	1520	32.75	6.60
6.70-15	1110	1190	1230	1290	1340	1400	1450	1500	1550	1600	1640	1680	1720	33.95	7.00
6.85-15	950	1000	1050	1100	1140	1190	1230	1270	1320	1360	1400	1440	1480	32.48	6.90
7.10-15	1170	1240	1310	1380	1440	1510	1580	1640	1700	1760	1820	1870	1930	36.02	7.35
7.35-15	1190	1270	1320	1380	1440	1500	1550	1600	1660	1710	1760	1810	1860	34.89	7.40
7.50-15	1270	1340	1400	1460	1520	1580	1640	1700	1760	1820	1870	1930	1990	33.86	7.50
7.60-15	1310	1400	1450	1520	1580	1640	1710	1760	1820	1880	1940	2000	2060	36.05	7.90
7.75-15	1350	1440	1500	1560	1620	1680	1740	1800	1860	1920	1980	2040	2100	34.53	7.65
8.00-15	1380	1470	1530	1600	1670	1730	1800	1860	1920	1980	2040	2100	2160	36.84	8.30
8.15-15	1420	1510	1570	1640	1710	1780	1840	1900	1960	2020	2080	2140	2200	35.50	8.15
8.20-15	1470	1570	1630	1700	1770	1840	1900	1960	2020	2080	2140	2200	2260	37.50	8.50
8.25-15	1510	1610	1670	1740	1810	1880	1940	2000	2060	2120	2180	2240	2300	35.57	8.20
8.45-15	1340	1410	1480	1550	1620	1680	1740	1800	1860	1920	1970	2030	2090	36.37	8.35
8.55-15	1360	1430	1510	1580	1640	1710	1770	1830	1890	1950	2000	2060	2120	36.57	8.45
8.85-15	1430	1510	1580	1650	1720	1790	1860	1920	1980	2040	2100	2160	2220	37.29	8.80
8.90-15	1430	1510	1580	1650	1720	1790	1860	1920	1980	2040	2100	2160	2220	37.29	8.90
9.00-15	1460	1540	1620	1690	1760	1830	1900	1970	2030	2090	2150	2210	2270	37.45	8.50
9.15-15	1510	1600	1680	1750	1830	1900	1970	2030	2100	2160	2220	2280	2340	37.92	9.05
5.00-16	815	860	910	975	990	1030	1070	1110	1150	1185	1220	1220	1220	31.03	5.15
6.00-16	1075	1135	1195	1250	1300	1350	1400	1450	1500	1550	1600	1650	1700	34.17	6.25
6.50-16	1150	1215	1280	1345	1405	1465	1525	1580	1635	1690	1740	1795	1850	35.59	6.80
6.70-16	1185	1245	1310	1375	1440	1505	1570	1635	1695	1760	1820	1880	1940	35.60	7.40
7.00-16	1260	1330	1400	1465	1535	1605	1675	1740	1810	1880	1950	2020	2090	37.02	7.35
7.50-16	1365	1440	1515	1585	1650	1715	1780	1840	1900	1960	2020	2080	2140	38.78	8.00
7.50-16	1365	1440	1515	1585	1650	1715	1780	1840	1900	1960	2020	2080	2140	38.78	8.00
6.50-17	1215	1275	1330	1390	1450	1510	1560	1620	1680	1740	1795	1850	1910	37.00	7.60
L84-15	1510	1600	1680	1750	1830	1900	1970	2030	2100	2160	2220	2280	2340	37.88	8.65

¹ The letters "H", "S" or "V" may be included in any specified tire size designation adjacent to or in place of the "dash".
² Actual section width and overall width shall not exceed the specified section width by more than 7 percent.

TABLE I-B
TIRE LOAD RATINGS, TEST RIMS, MINIMUM SIZE FACTORS, AND SECTION WIDTHS FOR "70 SERIES" BIAS PLY TIRES

Tire size designation ¹	Maximum tire loads (pounds) at various cold inflation pressures (p.s.i.)											Test rim width (inches)	Minimum size factor (inches)	Section width (inches)	
	16	18	20	22	24	26	28	30	32	34	36				38
A70-13	720	770	810	860	900	940	980	1,020	1,060	1,090	1,130	1,160	1,200	30.27	7.30
B70-13	780	840	890	930	980	1,030	1,070	1,110	1,150	1,190	1,230	1,270	1,300	30.86	7.35
C70-13	840	890	950	1,000	1,050	1,100	1,140	1,190	1,230	1,270	1,320	1,360	1,400	31.68	7.80
D70-13	890	950	1,010	1,070	1,120	1,170	1,220	1,270	1,320	1,360	1,410	1,450	1,490	32.34	8.00
E70-14	890	950	1,010	1,070	1,120	1,170	1,220	1,270	1,320	1,360	1,410	1,450	1,490	32.81	7.85
F70-14	950	1,010	1,070	1,130	1,190	1,240	1,300	1,350	1,400	1,440	1,490	1,540	1,580	33.45	8.05
G70-14	1,020	1,090	1,160	1,220	1,280	1,340	1,400	1,450	1,500	1,550	1,600	1,650	1,700	34.16	8.30
H70-14	1,100	1,180	1,250	1,310	1,380	1,440	1,500	1,560	1,620	1,680	1,730	1,780	1,830	35.18	8.75
J70-14	1,200	1,290	1,350	1,430	1,500	1,580	1,650	1,710	1,770	1,830	1,890	1,950	2,010	36.19	9.10
L70-14	1,260	1,350	1,430	1,500	1,580	1,650	1,720	1,790	1,860	1,920	1,980	2,040	2,100	36.87	9.50
M70-14	1,340	1,430	1,520	1,600	1,680	1,750	1,830	1,900	1,970	2,040	2,100	2,170	2,230	37.62	9.75
N70-15	720	770	810	860	900	940	980	1,020	1,060	1,090	1,130	1,160	1,200	30.99	6.60
O70-15	840	890	950	1,000	1,050	1,100	1,140	1,190	1,230	1,270	1,320	1,360	1,390	32.75	7.50
P70-15	890	950	1,010	1,070	1,120	1,170	1,220	1,270	1,320	1,360	1,410	1,450	1,490	33.37	7.70
Q70-15	950	1,010	1,070	1,130	1,190	1,240	1,300	1,350	1,400	1,440	1,490	1,540	1,580	34.13	8.10
R70-15	1,020	1,090	1,160	1,220	1,280	1,340	1,400	1,450	1,500	1,550	1,600	1,650	1,700	34.89	8.35
S70-15	1,100	1,180	1,250	1,310	1,380	1,440	1,500	1,560	1,620	1,680	1,730	1,780	1,830	35.66	8.60
T70-15	1,200	1,290	1,350	1,430	1,500	1,580	1,650	1,710	1,770	1,830	1,890	1,950	2,010	36.64	8.95
V70-15	1,260	1,350	1,430	1,500	1,580	1,650	1,720	1,790	1,860	1,920	1,980	2,040	2,100	37.36	9.35
W70-15	1,340	1,430	1,520	1,600	1,680	1,750	1,830	1,900	1,970	2,040	2,100	2,170	2,230	38.09	9.60

¹ The letters "H", "S" or "V" may be included in any specified tire size designation adjacent to or in place of the "dash".

² Actual section width and overall width shall not exceed the specified section width by more than 7 percent.

TABLE I-C
TIRE LOAD RATINGS, TEST RIMS, MINIMUM SIZE FACTORS, AND SECTION WIDTHS FOR BIAS PLY TIRES

Tire size designation ¹	Maximum tire loads (pounds) at various cold inflation pressures (p.s.i.)											Test rim width (inches)	Minimum size factor (inches)	Section width (inches)			
	16	18	20	22	24	26	28	30	32	34	36				38	40	
"Super Balloon" Sizes																	
4.80-10	320	355	390	430	470	490	510	535	555	575	595	615	635	655	3 1/2	23.90	5.00
5.20-10	350	395	440	485	530	555	575	605	625	650	670	695	715	735	3 1/2	24.84	5.20
5.20-10	385	430	475	515	550	580	605	630	650	675	700	725	750	775	4	24.00	5.80
5.20-12	395	445	495	545	595	625	655	685	710	735	760	785	810	835	3 1/2	26.79	5.20
5.60-12	460	520	575	620	670	715	760	795	825	855	885	915	940	965	4	27.83	5.71
5.90-12	505	565	620	670	720	765	810	855	885	915	945	975	1,005	1,035	4	26.00	5.90
6.20-12	505	565	620	670	720	765	810	855	885	915	945	975	1,005	1,035	4 1/2	27.00	6.30
5.20-13	430	485	540	590	640	670	710	740	765	795	820	850	875	905	3 1/2	27.72	5.20
5.60-13	495	560	620	675	725	770	810	850	880	910	945	975	1,005	1,035	4	28.92	5.71
5.90-13	555	625	695	755	815	860	895	935	970	1,005	1,040	1,075	1,105	1,135	4	29.74	5.91
6.20-13	520	580	640	700	750	780	820	850	880	910	945	975	1,005	1,035	4 1/2	28.00	6.30
6.40-13	630	705	785	845	915	945	985	1,025	1,060	1,100	1,140	1,175	1,210	1,245	4 1/2	31.26	6.42
6.70-13	690	775	860	935	1,000	1,045	1,090	1,135	1,175	1,220	1,260	1,305	1,340	1,375	4 1/2	32.14	6.69
6.90-13	695	745	795	845	895	915	955	1,005	1,045	1,085	1,120	1,160	1,195	1,230	5	30.00	7.20
5.20-14	475	535	595	645	695	735	785	825	855	885	915	945	975	1,005	3 1/2	28.89	5.20
5.60-14	530	595	660	715	770	815	855	890	920	955	990	1,020	1,050	1,080	4	29.94	5.71
5.90-14	585	660	730	785	850	880	925	970	1,005	1,040	1,080	1,115	1,145	1,175	4	30.76	5.91
6.40-14	660	745	825	890	960	1,000	1,040	1,080	1,120	1,170	1,210	1,250	1,290	1,330	4 1/2	32.19	6.42
6.45-14	660	745	825	890	960	1,000	1,040	1,080	1,120	1,170	1,210	1,250	1,290	1,330	4 1/2	30.92	6.60
5.20-15	505	570	630	685	740	780	830	870	900	935	965	1,000	1,030	1,060	3 1/2	29.75	5.20
5.60-15	555	625	695	755	815	860	895	935	970	1,005	1,040	1,075	1,105	1,135	4	30.87	5.71
5.90-15	615	695	770	825	890	935	980	1,015	1,070	1,090	1,130	1,165	1,200	1,235	4	31.77	5.91
6.40-15	660	745	825	890	960	1,000	1,040	1,080	1,120	1,170	1,210	1,250	1,290	1,330	4 1/2	33.20	6.42
"Low Section" Sizes																	
5.00-12	370	420	465	505	540	565	580	605	625	650	670	695	715	735	3 1/2	25.62	5.04
5.50-12	415	470	520	560	605	635	665	695	720	745	770	800	820	845	4	26.93	5.59
6.00-12	485	545	605	655	705	735	785	815	845	875	905	935	965	995	4 1/2	28.33	6.14
5.00-13	410	460	510	545	585	610	635	660	685	710	735	755	780	805	3 1/2	26.64	5.04
5.50-13	445	495	550	595	640	670	710	740	765	795	820	850	875	905	4	27.95	5.59
7.25-13	730	825	915	990	1,070	1,160	1,225	1,270	1,315	1,365	1,410	1,460	1,500	1,545	5	32.51	7.24
7.50-13	775	870	970	1,040	1,120	1,180	1,225	1,270	1,315	1,365	1,410	1,460	1,500	1,545	5 1/2	33.22	7.48
5.50-15L	505	570	630	675	725	760	800	840	870	900	935	965	995	1,025	4	29.97	5.59
6.00-15L	595	665	740	800	860	890	930	970	1,005	1,040	1,080	1,115	1,145	1,175	4 1/2	31.29	6.14
6.50-15L	675	755	840	900	970	1,010	1,060	1,105	1,145	1,185	1,230	1,270	1,305	1,340	4 1/2	32.66	6.54
7.00-15L	760	855	950	1,025	1,100	1,145	1,190	1,235	1,280	1,325	1,375	1,420	1,460	1,505	5	33.85	7.01

Tire size designation ¹	Maximum tire loads (pounds) at various cold inflation pressures (p.s.i.)												Test rim width (inches)	Minimum size factor (inches)	Section width (inches)
	16	18	20	22	24	26	28	30	32	34	36	38			
"Super Low Section" Sizes															
145-10/5.95-10	380	430	475	515	550	580	605	650	675	700	725	745	745	24.76	5.79
125-12/5.35-12	335	380	420	450	485	510	535	550	570	590	610	650	650	24.68	5.00
135-12/5.65-12	370	420	465	505	540	570	590	620	640	665	690	710	730	25.53	5.39
145-12/5.95-12	440	495	550	595	640	665	700	730	755	785	810	840	865	26.69	5.79
155-12/6.15-12	485	545	605	655	705	735	775	805	835	865	895	925	950	27.36	6.18
135-13/5.65-13	415	470	520	555	595	625	655	685	710	735	760	785	810	26.53	5.39
145-13/5.95-13	470	525	585	620	670	705	745	770	800	825	855	885	910	27.61	5.79
155-13/6.15-13	515	575	610	700	750	780	820	850	880	910	945	975	1,005	28.44	6.18
165-13/6.45-13	575	645	715	795	875	945	1,005	1,045	1,085	1,120	1,160	1,200	1,235	29.52	6.57
175-13/6.95-13	635	715	795	845	915	955	1,005	1,060	1,105	1,150	1,200	1,245	1,285	30.34	7.01
185-13/7.35-13	695	785	870	945	1,010	1,060	1,115	1,160	1,205	1,250	1,290	1,335	1,370	31.41	7.40
135-14/5.65-14	440	495	550	595	640	665	700	730	755	785	810	840	865	27.54	5.59
145-14/5.95-14	495	560	620	665	715	750	785	815	845	875	905	935	965	28.54	5.79
155-14/6.15-14	540	610	675	730	780	825	860	895	925	960	995	1,030	1,060	29.45	6.18
125-15/5.35-15	395	445	495	535	570	600	625	650	675	700	720	745	770	27.69	5.00
135-15/5.65-15	460	520	575	610	660	690	720	750	775	805	835	860	885	28.53	5.39
145-15/5.95-15	520	585	650	710	760	790	830	860	890	925	955	985	1,015	29.54	5.79
155-15/6.35-15	585	660	730	780	835	875	915	950	985	1,020	1,055	1,090	1,125	30.45	6.18
175-15/7.15-15	705	795	880	955	1,020	1,070	1,125	1,170	1,215	1,255	1,300	1,345	1,385	32.42	7.01
165-14	650	715	770	815	880	925	970	1,000	1,035	1,080	1,115	1,145	1,170	31.22	6.57
175-14	715	780	850	915	980	1,025	1,070	1,115	1,160	1,200	1,235	1,270	1,310	32.13	7.01
185-14	805	870	940	1,000	1,080	1,135	1,190	1,235	1,290	1,325	1,370	1,400	1,435	33.15	7.40
195-14	860	950	1,025	1,105	1,180	1,235	1,290	1,345	1,400	1,445	1,490	1,535	1,580	34.18	7.80
205-14	940	1,025	1,115	1,190	1,270	1,335	1,400	1,455	1,510	1,565	1,610	1,655	1,700	35.18	8.19
215-14	1,015	1,115	1,200	1,290	1,380	1,445	1,520	1,590	1,640	1,700	1,740	1,785	1,830	36.18	8.58
225-14	1,080	1,180	1,280	1,380	1,465	1,540	1,620	1,700	1,750	1,810	1,850	1,915	1,970	37.18	8.98
165-15	685	750	805	860	915	970	1,015	1,060	1,105	1,135	1,180	1,200	1,235	31.73	6.57
185-15	815	905	970	1,050	1,115	1,180	1,235	1,280	1,325	1,370	1,410	1,445	1,490	33.59	7.40
195-15	880	970	1,050	1,135	1,215	1,280	1,335	1,390	1,445	1,490	1,535	1,580	1,620	34.61	7.80
205-15	970	1,060	1,145	1,225	1,300	1,370	1,445	1,500	1,565	1,610	1,665	1,720	1,765	35.79	8.19
215-15	1,050	1,145	1,235	1,335	1,435	1,500	1,590	1,640	1,700	1,740	1,800	1,850	1,910	37.24	8.58
235-15	1,150	1,295	1,435	1,545	1,660	1,735	1,825	1,895	1,965	2,035	2,110	2,180	2,245	38.26	9.37
5.0-15	460	520	575	610	660	690	720	750	775	805	835	860	885	28.53	5.39
5.5-15	520	585	650	710	760	790	830	860	890	925	955	985	1,015	29.54	5.79

¹ The letters "H", "S" or "V" may be included in any specified tire size designation adjacent to or in place of the "dash".

² Actual section width and overall width shall not exceed the specified section width by more than 7 percent.

TABLE I-D
TIRE LOAD RATINGS, TEST RIMS, MINIMUM SIZE FACTORS, AND SECTION WIDTHS FOR DASH(-) RADIAL PLY TIRES

Tire size designation ¹	Maximum tire loads (pounds) at various cold inflation pressures (p.s.i.)											Test rim width (inches)	Minimum size factor (inches)	Section width (inches)		
	16	18	20	22	24	26	28	30	32	34	36				38	40
145-10.....	495	525	545	565	585	605	625	640	655	670	685	700	710	710	24.76	5.79
125-12.....	405	430	445	465	480	495	505	525	535	550	560	575	585	580	24.68	5.00
135-12.....	480	510	530	550	565	585	600	620	635	650	665	675	685	685	25.53	5.39
145-12.....	570	605	625	650	675	695	715	740	760	775	790	805	815	815	26.69	6.18
155-12.....	630	670	695	720	745	770	795	820	840	860	875	890	905	905	27.36	6.18
135-13.....	515	545	565	590	610	630	650	670	690	705	715	730	740	740	26.53	5.39
145-13.....	605	640	665	695	720	740	765	790	815	830	845	855	865	865	27.61	5.79
155-13.....	670	710	735	765	790	815	840	870	895	910	925	940	955	955	28.44	6.18
165-13.....	700	750	800	850	890	930	970	1,010	1,050	1,090	1,130	1,170	1,200	1,200	29.52	6.57
175-13.....	810	860	910	960	1,010	1,060	1,110	1,160	1,210	1,260	1,310	1,360	1,410	1,410	30.30	6.75
185-13.....	870	940	1,010	1,080	1,140	1,210	1,270	1,330	1,390	1,450	1,510	1,570	1,630	1,630	31.42	7.25
195-13.....	970	1,040	1,110	1,180	1,250	1,320	1,390	1,460	1,530	1,600	1,670	1,740	1,810	1,810	32.38	7.70
135-14.....	555	585	610	635	655	675	695	720	740	750	765	780	790	790	27.54	5.39
145-14.....	645	680	710	735	760	785	810	840	865	885	905	920	935	935	28.54	5.79
155-14.....	630	680	720	760	800	840	880	920	950	980	1,010	1,040	1,070	1,070	29.45	6.18
165-14.....	740	790	840	890	940	980	1,020	1,060	1,100	1,140	1,180	1,220	1,250	1,250	30.53	6.57
175-14.....	830	890	960	1,030	1,100	1,170	1,240	1,310	1,380	1,450	1,520	1,590	1,660	1,660	31.63	7.00
185-14.....	920	1,000	1,070	1,150	1,220	1,290	1,360	1,430	1,500	1,570	1,640	1,710	1,780	1,780	32.59	7.30
195-14.....	1,020	1,100	1,180	1,270	1,340	1,420	1,500	1,580	1,660	1,740	1,820	1,900	1,980	1,980	33.69	7.80
205-14.....	1,100	1,180	1,270	1,360	1,440	1,520	1,600	1,680	1,760	1,840	1,920	2,000	2,080	2,080	34.82	8.80
215-14.....	1,200	1,300	1,390	1,490	1,580	1,670	1,770	1,860	1,950	2,040	2,130	2,220	2,310	2,310	35.79	8.60
225-14.....	1,320	1,420	1,510	1,610	1,710	1,800	1,900	1,990	2,090	2,180	2,270	2,360	2,450	2,450	36.44	8.95
125-15.....	495	525	545	565	585	605	625	640	655	670	685	700	710	710	27.69	5.00
135-15.....	585	620	645	670	695	715	735	755	775	795	810	825	840	840	28.53	5.39
145-15.....	680	720	750	780	805	830	855	875	895	920	940	960	975	975	29.54	5.79
155-15.....	740	785	815	850	880	905	930	955	980	1,005	1,025	1,045	1,065	1,065	30.45	6.18
165-15.....	820	870	900	920	970	1,020	1,070	1,110	1,150	1,190	1,230	1,270	1,310	1,310	31.45	6.57
175-15.....	925	980	1,020	1,060	1,095	1,130	1,170	1,210	1,250	1,300	1,340	1,400	1,440	1,440	32.41	7.00
185-15.....	1,000	1,070	1,140	1,210	1,280	1,350	1,420	1,490	1,560	1,620	1,680	1,740	1,800	1,800	33.04	6.62
195-15.....	1,080	1,160	1,240	1,320	1,400	1,470	1,550	1,620	1,700	1,780	1,840	1,920	2,000	2,000	34.22	7.45
205-15.....	1,190	1,280	1,370	1,450	1,530	1,610	1,690	1,770	1,850	1,930	2,010	2,090	2,170	2,170	35.20	8.10
215-15.....	1,320	1,420	1,520	1,610	1,695	1,785	1,875	1,965	2,055	2,145	2,235	2,325	2,415	2,415	36.00	8.35
225-15.....	1,470	1,570	1,670	1,770	1,865	1,960	2,055	2,150	2,245	2,340	2,435	2,530	2,625	2,625	36.94	8.80
235-15.....	1,405	1,515	1,625	1,725	1,825	1,925	2,025	2,125	2,225	2,325	2,425	2,525	2,625	2,625	37.30	8.80
240-15.....	1,430	1,540	1,640	1,740	1,840	1,940	2,040	2,140	2,240	2,340	2,440	2,540	2,640	2,640	37.75	9.05
185-16.....	1,455	1,570	1,680	1,790	1,890	1,990	2,090	2,190	2,290	2,390	2,490	2,590	2,690	2,690	38.28	9.05
165-400.....	800	860	920	980	1,030	1,080	1,130	1,180	1,220	1,260	1,300	1,340	1,380	1,380	34.14	7.40
															32.04	6.62

¹ The letters "H", "S", or "V" may be included in any specified tire size designation adjacent to or in place of the "dash".
² Actual section width and overall width shall not exceed the specified section width by more than 7 percent.

TABLE I-E
TIRE LOAD RATINGS, TEST RIMS, MINIMUM SIZE FACTORS, AND SECTION WIDTHS FOR "77 SERIES" BIAS PLY TIRES

Tire size designation ¹	Maximum tire loads (pounds) at various cold inflation pressures (p.s.i.)											Test rim width (inches)	Minimum size factor (inches)	Section width (inches)	
	16	18	20	22	24	26	28	30	32	34	36				38
G77-14	385	430	475	515	550	580	605	630	660	675	700	780	830	35.04	8.45
5.9-10	460	505	550	595	640	665	700	730	755	785	810	925	950	24.00	5.80
5.9-12	485	545	605	655	705	735	775	805	835	865	895	925	950	26.00	5.90
6.2-12	515	575	640	700	750	780	820	850	880	910	945	975	1,005	27.21	6.06
6.5-13	575	645	715	770	825	865	905	935	970	1,005	1,040	1,075	1,105	28.19	6.06
6.9-13	635	715	795	845	915	955	1,005	1,045	1,085	1,120	1,160	1,190	1,225	29.18	6.54
6.2-15	585	660	730	780	835	875	915	950	985	1,020	1,055	1,090	1,125	29.92	6.77
6.9-15	705	795	880	955	1,020	1,070	1,125	1,170	1,215	1,255	1,300	1,345	1,385	30.17	6.77

¹ The letters "H", "S", or "V" may be included in any specified tire size designation adjacent to or in place of the "dash".
² Actual section width and overall width shall not exceed the specified section width by more than 7 percent.

TABLE I-F
TIRE LOAD RATINGS, TEST RIMS, MINIMUM SIZE FACTORS, AND SECTION WIDTHS FOR TYPE "R" RADIAL PLY TIRES

Tire size designation ¹	Maximum tire loads (pounds) at various cold inflation pressures (p.s.i.)											Test rim width (inches)	Minimum size factor (inches)	Section width (inches)		
	16	18	20	22	24	26	28	30	32	34	36				38	40
5.20R10.....	435	460	485	510	535	560	585	615	635	660	685	710	735	3½	24.84	5.20
5.00R12.....	480	495	515	535	555	575	595	615	635	650	670	690	710	3½	25.62	5.04
5.20R12.....	515	540	565	590	615	640	665	695	715	740	775	790	815	3½	26.79	5.20
5.50R12.....	520	545	570	595	620	650	670	705	725	750	785	800	825	4	26.93	5.59
5.60R12.....	600	630	655	685	715	740	770	800	825	850	875	905	930	4	27.83	5.71
5.00R13.....	535	555	590	615	630	645	670	690	705	725	745	765	785	3½	26.64	5.04
5.20R13.....	570	595	620	645	670	695	720	750	770	795	820	845	870	3½	27.72	5.20
5.50R13.....	575	600	625	650	675	695	725	755	775	795	825	850	875	4	27.95	5.59
5.60R13.....	655	685	710	740	765	795	825	855	880	905	935	960	990	4	28.92	5.71
5.90R13.....	705	780	805	830	860	885	915	940	965	990	1,015	1,045	1,070	4	29.37	6.00
6.40R13.....	810	840	870	905	940	970	1,005	1,040	1,070	1,100	1,135	1,165	1,200	4½	29.74	5.91
6.50R13.....	800	830	860	890	925	960	995	1,030	1,060	1,090	1,120	1,150	1,180	4½	31.26	6.42
6.70R13.....	890	910	950	985	1,025	1,060	1,100	1,135	1,175	1,220	1,260	1,305	1,340	4½	30.75	6.60
7.00R13.....	940	980	1,020	1,060	1,100	1,135	1,175	1,215	1,255	1,290	1,330	1,370	1,410	5	31.88	7.10
7.25R13.....	605	640	670	700	730	760	795	830	855	885	915	950	980	5	32.51	7.24
5.20R14.....	750	785	815	845	875	905	935	970	995	1,025	1,055	1,085	1,115	3½	28.89	5.20
5.90R14.....	925	960	1,000	1,040	1,075	1,115	1,155	1,195	1,235	1,270	1,320	1,350	1,380	4	30.76	5.91
7.50R14.....	1,065	1,100	1,140	1,180	1,220	1,260	1,300	1,340	1,380	1,415	1,460	1,500	1,540	5	32.88	7.10
7.50R14.....	705	780	805	830	860	885	915	940	965	990	1,015	1,045	1,070	5½	34.19	7.65
5.60R15.....	885	925	965	1,005	1,040	1,080	1,120	1,160	1,200	1,235	1,275	1,310	1,350	4	30.87	5.71
6.40R15.....	975	1,015	1,055	1,095	1,130	1,170	1,215	1,255	1,290	1,325	1,365	1,405	1,445	4½	33.26	6.42
7.60R15.....	1,160	1,200	1,245	1,285	1,325	1,370	1,415	1,465	1,500	1,535	1,575	1,610	1,655	5½	33.95	7.00
7.60R15.....	1,160	1,200	1,245	1,285	1,325	1,370	1,415	1,465	1,500	1,535	1,575	1,610	1,655	5½	36.00	7.90

¹ The letters "H", "S", or "V" may be included in any specified tire size designation adjacent to the "R".
² Actual section width and overall width shall not exceed the specified section width by more than 7 percent.

TABLE I-G
TIRE LOAD RATINGS, TEST RIMS, MINIMUM SIZE FACTORS, AND SECTION WIDTHS FOR "70 SERIES" RADIAL PLY TIRES

Tire size designation ¹	Maximum tire loads (pounds) at various cold inflation pressures (p.s.i.)											Test rim width (inches)	Minimum size factor (inches)	Section width (inches)	
	16	18	20	22	24	26	28	30	32	34	36				38
AR70-13	720	770	810	860	900	940	980	1,020	1,060	1,090	1,130	1,160	1,200	30.04	7.15
BR70-13	780	840	890	930	980	1,030	1,070	1,110	1,150	1,190	1,230	1,270	1,300	31.04	7.60
CR70-13	840	890	950	1,000	1,050	1,100	1,140	1,190	1,230	1,270	1,320	1,360	1,400	31.65	7.85
DR70-13	890	950	1,010	1,070	1,120	1,170	1,220	1,270	1,320	1,360	1,410	1,450	1,490	32.29	8.05
ER70-14	840	890	950	1,000	1,050	1,100	1,140	1,190	1,230	1,270	1,320	1,360	1,400	32.23	7.65
FR70-14	890	950	1,010	1,070	1,120	1,170	1,220	1,270	1,320	1,360	1,410	1,450	1,490	32.78	7.90
GR70-14	950	1,010	1,070	1,130	1,190	1,240	1,300	1,350	1,400	1,440	1,490	1,540	1,580	33.42	8.10
HR70-14	1,020	1,090	1,160	1,220	1,280	1,340	1,400	1,450	1,500	1,550	1,600	1,650	1,700	34.34	8.55
JR70-14	1,100	1,180	1,250	1,310	1,380	1,440	1,500	1,560	1,620	1,680	1,730	1,780	1,830	35.12	8.85
KR70-14	1,200	1,290	1,360	1,440	1,510	1,580	1,650	1,710	1,770	1,830	1,890	1,950	2,010	36.31	9.40
LR70-14	1,340	1,430	1,520	1,600	1,680	1,750	1,830	1,900	1,970	2,040	2,100	2,170	2,230	36.86	9.55
DR70-15	890	950	1,010	1,070	1,120	1,170	1,220	1,270	1,320	1,360	1,410	1,450	1,490	37.59	9.80
ER70-15	950	1,010	1,070	1,130	1,190	1,240	1,300	1,350	1,400	1,440	1,490	1,540	1,580	38.34	10.05
FR70-15	1,020	1,090	1,160	1,220	1,280	1,340	1,400	1,450	1,500	1,550	1,600	1,650	1,700	39.11	10.30
GR70-15	1,100	1,180	1,250	1,310	1,380	1,440	1,500	1,560	1,620	1,680	1,730	1,780	1,830	40.00	10.65
HR70-15	1,200	1,290	1,360	1,440	1,510	1,580	1,650	1,710	1,770	1,830	1,890	1,950	2,010	40.87	11.00
JR70-15	1,260	1,350	1,430	1,500	1,580	1,660	1,720	1,790	1,860	1,920	1,980	2,040	2,100	41.75	11.35
KR70-15	1,340	1,430	1,520	1,600	1,680	1,760	1,830	1,900	1,970	2,040	2,100	2,170	2,230	42.63	11.70
LR70-15	1,420	1,520	1,610	1,700	1,780	1,860	1,940	2,020	2,090	2,160	2,230	2,300	2,370	43.51	12.05

¹ The letters "HR", "SR" or "VR" may be included in any specified tire size designation adjacent to or in place of the "dash".
² Actual section width and overall width shall not exceed the specified section width by more than 7 percent.

TABLE I-H
TIRE LOAD RATINGS, TEST RIMS, MINIMUM SIZE FACTORS, AND SECTION WIDTHS FOR TYPE "R" RADIAL PLY TIRES

Tire size designation ¹	Maximum tire loads (pounds) at various cold inflation pressures (p.s.i.)												Test rim width (inches)	Minimum size factor (inches)	Section width (inches)
	16	18	20	22	24	26	28	30	32	34	36	38			
145R10	465	495	525	550	580	605	630	655	680	700	725	750	770	24.76	5.79
125R12	370	400	430	450	475	495	515	535	555	575	595	610	630	24.68	5.00
135R12	440	475	505	535	560	585	610	635	655	680	700	725	745	25.53	5.39
145R12	530	565	600	635	665	695	725	755	780	810	835	860	885	26.69	5.79
155R12	590	630	665	700	735	770	800	835	865	895	925	950	980	27.36	6.18
135R13	480	515	545	575	600	630	655	680	705	730	755	780	800	26.53	5.39
145R13	590	630	665	700	735	770	800	835	860	890	920	945	980	27.59	5.79
155R13	645	690	730	770	810	845	885	915	950	985	1,015	1,045	1,075	28.44	6.18
165R13	680	730	770	820	860	900	930	970	1,010	1,040	1,080	1,110	1,140	29.18	6.40
175R13	790	840	890	930	980	1,030	1,070	1,110	1,150	1,190	1,230	1,270	1,300	30.30	6.75
185R13	870	930	980	1,030	1,080	1,130	1,180	1,230	1,270	1,310	1,360	1,400	1,440	31.42	7.25
195R13	955	1,010	1,060	1,110	1,170	1,220	1,280	1,320	1,370	1,420	1,470	1,510	1,550	32.38	7.70
135R14	515	550	585	615	645	675	705	730	760	785	810	835	860	27.54	5.39
145R14	595	635	675	715	750	785	815	850	880	910	940	965	995	28.54	5.79
155R14	690	740	780	820	860	900	940	970	1,010	1,040	1,080	1,110	1,140	29.51	6.05
165R14	760	810	860	910	960	1,000	1,040	1,080	1,120	1,160	1,200	1,240	1,270	30.65	6.55
175R14	840	900	950	1,000	1,050	1,100	1,140	1,190	1,230	1,270	1,310	1,350	1,390	31.63	7.00
185R14	920	980	1,040	1,100	1,160	1,210	1,260	1,310	1,360	1,400	1,450	1,490	1,540	32.59	7.30
195R14	1,020	1,090	1,150	1,210	1,270	1,330	1,390	1,440	1,500	1,550	1,600	1,650	1,690	33.69	7.80
205R14	1,110	1,190	1,250	1,310	1,380	1,440	1,500	1,560	1,620	1,670	1,730	1,780	1,830	34.82	8.30
215R14	1,210	1,290	1,360	1,430	1,510	1,580	1,640	1,710	1,770	1,830	1,890	1,950	2,000	35.79	8.60
225R14	1,270	1,350	1,430	1,510	1,580	1,660	1,730	1,790	1,860	1,920	1,990	2,050	2,100	36.44	8.95
125R15	460	490	520	550	575	605	630	655	680	705	725	745	770	27.69	5.00
135R15	545	580	615	650	680	715	745	775	800	830	855	880	910	28.53	5.39
145R15	640	680	720	760	795	830	865	900	935	965	995	1,025	1,055	29.54	5.79
155R15	690	735	780	825	865	905	940	980	1,015	1,050	1,085	1,115	1,150	30.45	6.18
165R15	770	820	870	910	960	1,000	1,050	1,090	1,130	1,170	1,200	1,240	1,270	31.18	6.40
175R15	840	900	950	1,000	1,050	1,100	1,140	1,190	1,230	1,270	1,320	1,360	1,390	32.30	6.90
185R15	950	1,010	1,070	1,130	1,180	1,240	1,290	1,340	1,390	1,440	1,490	1,530	1,570	33.58	7.45
195R15	1,020	1,090	1,150	1,210	1,270	1,330	1,380	1,440	1,490	1,550	1,600	1,640	1,690	34.22	7.65
205R15	1,100	1,170	1,240	1,300	1,370	1,430	1,490	1,550	1,610	1,660	1,720	1,770	1,820	35.20	8.10
215R15	1,190	1,270	1,340	1,410	1,480	1,550	1,620	1,680	1,740	1,800	1,860	1,920	1,970	36.00	8.35
225R15	1,270	1,350	1,430	1,510	1,580	1,650	1,720	1,790	1,860	1,920	1,980	2,040	2,100	36.94	8.80
235R15	1,340	1,430	1,510	1,600	1,680	1,750	1,830	1,900	1,970	2,030	2,100	2,160	2,220	37.75	9.05
206R16	1,100	1,170	1,240	1,300	1,370	1,430	1,490	1,550	1,610	1,660	1,720	1,770	1,820	36.52	8.19

¹ The letters "H", "S" or "V" may be included in any specified tire size designation adjacent to the "R".
² Actual section width and overall width shall not exceed the specified section width by more than 7 percent.

TABLE I-J
TIRE LOAD RATINGS, TEST RIMS, MINIMUM SIZE FACTORS, AND SECTION WIDTHS FOR "78 SERIES" BIAS PLY TIRES

Tire size designation ¹	Maximum tire loads (pounds) at various cold inflation pressures (p.s.i.)											Test rim width (inches)	Minimum size factor (inches)	Section width (inches)	
	16	18	20	22	24	26	28	30	32	34	36				38
A78-13	720	770	810	860	900	940	980	1,020	1,060	1,090	1,130	1,160	1,200	29.74	6.60
B78-13	780	840	890	930	980	1,030	1,070	1,110	1,150	1,190	1,230	1,270	1,300	30.72	7.05
C78-13	840	890	950	1,000	1,050	1,100	1,140	1,190	1,230	1,270	1,320	1,360	1,400	31.56	7.45
D78-13	890	950	1,010	1,070	1,120	1,170	1,220	1,270	1,320	1,360	1,410	1,450	1,490	32.18	7.70
A78-14	720	770	810	860	900	940	980	1,020	1,060	1,090	1,130	1,160	1,200	30.31	6.45
B78-14	780	840	890	930	980	1,030	1,070	1,110	1,150	1,190	1,230	1,270	1,300	31.04	6.65
C78-14	840	890	950	1,000	1,050	1,100	1,140	1,190	1,230	1,270	1,320	1,360	1,400	31.95	7.05
D78-14	890	950	1,010	1,070	1,120	1,170	1,220	1,270	1,320	1,360	1,410	1,450	1,490	32.52	7.35
E78-14	950	1,010	1,070	1,130	1,190	1,240	1,300	1,350	1,400	1,440	1,490	1,540	1,580	33.29	7.65
F78-14	1,020	1,090	1,160	1,220	1,280	1,340	1,400	1,450	1,500	1,550	1,600	1,650	1,700	34.04	7.90
G78-14	1,100	1,180	1,250	1,310	1,380	1,440	1,500	1,560	1,620	1,680	1,730	1,780	1,830	35.02	8.35
H78-14	1,200	1,290	1,360	1,440	1,510	1,580	1,650	1,710	1,770	1,830	1,890	1,950	2,010	36.06	8.70
J78-14	1,260	1,350	1,430	1,500	1,580	1,650	1,720	1,790	1,860	1,920	1,980	2,040	2,100	36.58	8.80
A78-15	720	770	810	860	900	940	980	1,020	1,060	1,090	1,130	1,160	1,200	30.85	6.35
B78-15	780	840	890	950	1,000	1,050	1,100	1,140	1,190	1,230	1,270	1,320	1,360	32.45	6.95
C78-15	840	890	950	1,010	1,070	1,120	1,170	1,220	1,270	1,320	1,360	1,410	1,450	33.05	7.15
D78-15	890	950	1,010	1,070	1,120	1,170	1,220	1,270	1,320	1,360	1,410	1,450	1,490	33.65	7.35
E78-15	950	1,010	1,070	1,130	1,190	1,240	1,300	1,350	1,400	1,440	1,490	1,540	1,580	34.56	7.70
F78-15	1,020	1,090	1,160	1,220	1,280	1,340	1,400	1,450	1,500	1,550	1,600	1,650	1,700	35.36	8.05
G78-15	1,100	1,180	1,250	1,310	1,380	1,440	1,500	1,560	1,620	1,680	1,730	1,780	1,830	36.50	8.55
H78-15	1,200	1,290	1,360	1,440	1,510	1,580	1,650	1,710	1,770	1,830	1,890	1,950	2,010	37.02	8.70
J78-15	1,260	1,340	1,430	1,520	1,600	1,680	1,750	1,830	1,900	1,970	2,040	2,100	2,230	37.73	8.85
N78-15	1,500	1,600	1,700	1,790	1,880	1,970	2,050	2,130	2,210	2,280	2,360	2,430	2,500	39.50	9.80

¹ The letters "H", "S", or "V" may be included in any specified tire size designation adjacent to or in place of the "dash".

² Actual section width and overall width shall not exceed the specified section width by more than 7 percent.

TABLE I-K
TIRE LOAD RATINGS, TEST RIMS, MINIMUM SIZE FACTORS, AND SECTION WIDTHS FOR "60 SERIES" BIAS PLY TIRES

Tire size designation ¹	Maximum tire loads (pounds) at various cold inflation pressures (p.s.i.)											Test rim width (inches)	Minimum size factor (inches)	Section width (inches)			
	16	18	20	22	24	26	28	30	32	34	36				38	40	
A60-13	720	770	810	860	900	940	980	1020	1060	1090	1130	1160	1200	1300	7.85	30.00	7.85
B60-13	780	840	890	930	980	1030	1070	1110	1150	1190	1230	1270	1300	1400	8.35	30.95	8.35
C60-13	840	890	950	1000	1050	1100	1140	1190	1230	1270	1320	1360	1400	1500	8.60	31.58	8.60
D60-13	890	950	1010	1070	1120	1170	1220	1270	1320	1360	1410	1450	1490	1600	8.85	32.20	8.85
B60-14	780	840	890	930	980	1030	1070	1110	1150	1190	1230	1270	1300	1400	8.00	31.26	8.00
C60-14	840	890	950	1000	1050	1100	1140	1190	1230	1270	1320	1360	1400	1500	8.45	32.09	8.45
D60-14	890	950	1010	1070	1120	1170	1220	1270	1320	1360	1410	1450	1490	1600	8.65	32.72	8.65
E60-14	950	1010	1070	1130	1190	1240	1300	1350	1400	1440	1490	1540	1580	1700	9.30	33.69	9.30
F60-14	1020	1090	1160	1220	1280	1340	1400	1450	1500	1550	1600	1650	1700	1830	9.55	34.44	9.55
G60-14	1100	1180	1250	1310	1380	1440	1500	1560	1620	1680	1730	1780	1830	2010	9.85	35.23	9.85
H60-14	1200	1290	1360	1440	1510	1580	1650	1710	1770	1830	1890	1950	2010	2230	10.25	36.20	10.25
J60-14	1260	1350	1430	1500	1580	1650	1720	1790	1860	1920	1980	2040	2100	2350	10.45	36.70	10.45
L60-14	1340	1430	1520	1600	1680	1750	1830	1900	1970	2040	2100	2170	2230	2500	11.10	37.83	11.10
M60-14	780	840	890	930	980	1030	1070	1110	1150	1190	1230	1270	1300	1400	7.80	31.85	7.80
N60-14	840	890	950	1000	1050	1100	1140	1190	1230	1270	1320	1360	1400	1500	8.25	32.66	8.25
O60-14	950	1010	1070	1130	1190	1240	1300	1350	1400	1440	1490	1540	1580	1700	8.70	33.83	8.70
P60-14	1020	1090	1160	1220	1280	1340	1400	1450	1500	1550	1600	1650	1700	1830	9.40	34.75	9.40
Q60-14	1100	1180	1250	1310	1380	1440	1500	1560	1620	1680	1730	1780	1830	2010	9.70	35.73	9.70
R60-14	1200	1290	1360	1440	1510	1580	1650	1710	1770	1830	1890	1950	2010	2230	10.05	36.70	10.05
S60-14	1260	1350	1430	1500	1580	1650	1720	1790	1860	1920	1980	2040	2100	2350	10.25	37.20	10.25
T60-14	1340	1430	1520	1600	1680	1750	1830	1900	1970	2040	2100	2170	2230	2500	10.50	37.91	10.50

¹ The letters "H", "S", or "V" may be included in any specified tire size designation adjacent to or in place of the "dash".
² Actual section width and overall width shall not exceed the specified section width by more than 7 percent.

TABLE I-L
TIRE LOAD RATINGS, TEST RIMS, MINIMUM SIZE FACTORS, AND SECTION WIDTHS FOR "50 SERIES" CANTILEVERED SIDEWALL TIRES

Tire size designation ¹	Maximum tire loads (pounds) at various cold inflation pressures (p.s.i.)											Test rim width (inches)	Minimum size factor (inches)	Section width (inches)			
	16	18	20	22	24	26	28	30	32	34	36				38	40	
E50C-16	1070	1130	1190	1240	1300	1340	1400	1450	1500	1550	1600	1650	1700	1830	7.95	33.31	7.95
F50C-16	1160	1220	1280	1340	1400	1440	1500	1550	1600	1650	1700	1750	1800	1950	8.20	34.04	8.20
G50C-17	1250	1310	1380	1440	1500	1540	1600	1620	1680	1730	1780	1830	1880	2010	8.45	35.34	8.45
H50C-17	1360	1440	1510	1580	1650	1710	1770	1830	1890	1950	2010	2070	2130	2300	8.80	36.30	8.80
L50C-18	1520	1600	1680	1750	1830	1900	1970	2040	2100	2170	2230	2300	2370	2550	9.10	38.00	9.10

¹ The letters "H", "S", or "V" may be included in any specified tire size designation adjacent to or in place of the "dash".
² Actual section width and overall width shall not exceed the specified section width by more than 7 percent.

TABLE I-M
TIRE LOAD RATINGS, TEST RIMS, MINIMUM SIZE FACTORS, AND SECTION WIDTHS FOR "78 SERIES" RADIAL PLY TIRES

Tire size designation ¹	Maximum tire loads (pounds) at various cold inflation pressures (p.s.i.)										Test rim width (inches)		Minimum size factor (inches)	Section width (inches)	
	16	18	20	22	24	26	28	30	32	34	36	38			40
AR78-13	720	770	810	860	900	940	980	1,020	1,060	1,090	1,130	1,160	1,200	29.55	6.50
BR78-13	780	840	890	930	980	1,030	1,070	1,110	1,150	1,190	1,230	1,270	1,300	30.31	6.75
CR78-13	840	890	950	1,000	1,050	1,100	1,140	1,190	1,230	1,270	1,320	1,360	1,400	31.13	7.15
AR78-14	720	770	810	860	900	940	980	1,020	1,060	1,090	1,130	1,160	1,200	30.08	6.40
BR78-14	780	840	890	930	980	1,030	1,070	1,110	1,150	1,190	1,230	1,270	1,300	30.84	6.60
CR78-14	840	890	950	1,000	1,050	1,100	1,140	1,190	1,230	1,270	1,320	1,360	1,400	31.67	7.00
DR78-14	890	950	1,010	1,070	1,120	1,170	1,220	1,270	1,320	1,360	1,410	1,450	1,490	32.26	7.20
ER78-14	950	1,010	1,070	1,130	1,190	1,240	1,300	1,350	1,400	1,440	1,490	1,540	1,580	32.86	7.40
FR78-14	1,020	1,090	1,160	1,220	1,280	1,340	1,400	1,450	1,500	1,550	1,610	1,650	1,700	33.78	7.85
GR78-14	1,100	1,180	1,250	1,310	1,380	1,440	1,500	1,560	1,620	1,680	1,730	1,780	1,830	34.78	8.30
HR78-14	1,200	1,290	1,360	1,440	1,510	1,580	1,650	1,710	1,770	1,830	1,890	1,950	2,010	35.77	8.60
IR78-14	1,260	1,350	1,430	1,500	1,580	1,650	1,720	1,790	1,860	1,920	1,980	2,040	2,100	36.47	8.95
AR78-15	720	770	810	860	900	940	980	1,020	1,060	1,090	1,130	1,160	1,200	30.66	6.25
BR78-15	780	840	890	930	980	1,030	1,070	1,110	1,150	1,190	1,230	1,270	1,300	31.38	6.45
CR78-15	840	890	950	1,000	1,050	1,100	1,140	1,190	1,230	1,270	1,320	1,360	1,400	32.24	6.85
ER78-15	950	1,010	1,070	1,130	1,190	1,240	1,300	1,350	1,400	1,440	1,490	1,540	1,580	33.58	7.45
FR78-15	1,020	1,090	1,160	1,220	1,280	1,340	1,400	1,450	1,500	1,550	1,610	1,650	1,700	34.28	7.70
GR78-15	1,100	1,180	1,250	1,310	1,380	1,440	1,500	1,560	1,620	1,680	1,730	1,780	1,830	35.30	8.15
HR78-15	1,200	1,290	1,360	1,440	1,510	1,580	1,650	1,710	1,770	1,830	1,890	1,950	2,010	36.23	8.45
IR78-15	1,260	1,350	1,430	1,500	1,580	1,650	1,720	1,790	1,860	1,920	1,980	2,040	2,100	36.98	8.80
KR78-15	1,290	1,380	1,460	1,540	1,620	1,690	1,770	1,830	1,900	1,970	2,030	2,090	2,150	37.03	8.70
LR78-15	1,340	1,430	1,520	1,600	1,680	1,750	1,830	1,900	1,970	2,040	2,100	2,170	2,230	37.66	9.00
MR78-15	1,420	1,520	1,610	1,700	1,780	1,860	1,940	2,020	2,090	2,160	2,230	2,300	2,370	38.35	9.20
NR78-15	1,500	1,600	1,700	1,790	1,880	1,970	2,050	2,130	2,210	2,280	2,360	2,430	2,500	39.17	9.71

¹ The letters "H", "S", or "V" may be included in any specified tire size designation adjacent to or in place of the "dash".
² Actual section width and overall width shall not exceed the specified section width by more than 7 percent.

TABLE I-N
TIRE LOAD RATINGS, TEST RIMS, MINIMUM SIZE FACTORS, AND SECTION WIDTHS FOR "70 SERIES" RADIAL PLY TIRES

Tire size designation ¹	Maximum tire loads (pounds) at various cold inflation pressures (p.s.i.)										Test rim width (inches)		Minimum size factor (inches)	Section width (inches)	
	16	18	20	22	24	26	28	30	32	34	36	38			40
155/70R13	630	650	665	685	705	725	740	760	780	800	820	835	855	27.17	5.93
155/70R15	690	710	730	750	770	790	810	830	850	870	890	910	930	29.20	5.93

¹ The letters "H", "S", or "V" may be included in any specified tire size designation adjacent to or in place of the "dash".
² Actual section width and overall width shall not exceed the specified section width by more than 7 percent.

TABLE I-O
TIRE LOAD RATINGS, TEST RIMS, MINIMUM SIZE FACTORS, AND SECTION WIDTHS FOR "LOW SECTION" TYPE "R" RADIAL PLY TIRES

Tire size designation ¹	Maximum tire loads (pounds) at various cold inflation pressures (p.s.i.)										Test rim width (inches)	Minimum size factor (inches)	Section width ² (inches)	
	20	22	24	26	28	30	32	34	36	38				40
140R12	490	520	550	580	610	640	660	690	710	740	770	4	26.20	5.40
150R12	570	610	640	670	700	730	760	790	820	850	880	4	27.19	5.75
150R13	600	640	680	720	750	780	810	840	870	900	940	4	28.17	5.75
160R13	670	700	740	780	820	860	900	940	980	1,010	1,040	4½	29.23	6.25
170R13	720	760	800	840	880	920	960	1,000	1,000	1,080	1,110	5	30.08	6.60
150R14	640	670	710	750	780	820	860	900	940	970	1,000	4	29.16	5.75
180R15	920	970	1,020	1,070	1,120	1,170	1,220	1,280	1,330	1,380	1,430	5	32.97	6.85

¹ The letters "H", "S" or "V" may be included in any specified tire size designation adjacent to the "R".
² Actual section width and overall width shall not exceed the specified section width by more than 7 percent.

TABLE I-P
TIRE LOAD RATINGS, TEST RIMS, MINIMUM SIZE FACTORS, AND SECTION WIDTHS FOR SERIES 45 CANTILEVERED SIDEWALL TIRES

Tire size designation ¹	Maximum tire loads (pounds) at various cold inflation pressures (p.s.i.)										Test rim width (inches)	Minimum size factor (inches)	Section width ² (inches)	
	20	22	24	26	28	30	32	34	36	38				40
G45C-16	1,250	1,310	1,380	1,440	1,500	1,560	1,620	1,680	1,730	1,780	1,830	5	35.53	9.70

¹ The letter "H", "S" or "V" may be included in any specified tire size designation adjacent to or in place of the "dash".
² Actual section width and overall width shall not exceed the specified section width by more than 7 percent.

TABLE I-R
TIRE LOAD RATINGS, TEST RIMS, MINIMUM SIZE FACTORS, AND SECTION WIDTHS FOR "60 SERIES" RADIAL PLY TIRES

Tire size designation ¹	Maximum tire loads (pounds) at various cold inflation pressures (p.s.i.)										Test rim width (inches)	Minimum size factor (inches)	Section width (inches)			
	16	18	20	22	24	26	28	30	32	34				36	38	40
CR60-13	840	890	950	1,000	1,050	1,100	1,140	1,190	1,230	1,270	1,320	1,360	1,400	6	31.58	8.60
DR60-14	890	950	1,010	1,070	1,120	1,170	1,220	1,270	1,320	1,360	1,410	1,450	1,490	6	32.72	8.65
ER60-14	950	1,010	1,070	1,130	1,190	1,240	1,300	1,350	1,400	1,440	1,490	1,540	1,580	6½	33.50	9.10

¹ The letters "H", "S" or "V" may be included in any tire size designation adjacent to the "R".
² Actual section width and overall width shall not exceed the specified section width by more than 7 percent.

TABLE I-S
TIRE LOAD RATINGS, TEST RIMS, MINIMUM SIZE FACTORS, AND SECTION WIDTHS FOR "60 SERIES" RADIAL PLY TIRES

Tire size designation ¹	Maximum tire loads (pounds) at various cold inflation pressures (p.s.i.)										Test rim width (inches)	Minimum size factor (inches)	Section width (inches)			
	16	18	20	22	24	26	28	30	32	34				36	38	40
235/60R13.....	950	1,010	1,070	1,130	1,190	1,240	1,300	1,350	1,400	1,440	1,490	1,540	1,580	6	32.81	9.05

¹ The letters "H", "S" or "V" may be included in any tire size designation adjacent to the "R".
² Actual section width and overall width shall not exceed the specified section width by more than 7 percent.

TABLE I-T
TIRE LOAD RATINGS, TEST RIMS, MINIMUM SIZE FACTORS, AND SECTION WIDTHS FOR "70 SERIES" RADIAL PLY TIRES

Tire size designation ¹	Maximum tire loads (pounds) at various cold inflation pressures (p.s.i.)										Test rim width (inches)	Minimum size factor (inches)	Section width (inches)			
	16	18	20	22	24	26	28	30	32	34				36	38	40
205/70R13.....	890	950	1,010	1,070	1,120	1,170	1,220	1,270	1,320	1,360	1,410	1,450	1,490	5½	32.29	8.05
205/70R14.....	950	1,010	1,070	1,130	1,190	1,240	1,300	1,350	1,400	1,440	1,490	1,540	1,580	5½	33.42	8.10
215/70R14.....	1,020	1,090	1,160	1,220	1,280	1,340	1,400	1,450	1,500	1,550	1,610	1,650	1,700	6	34.34	8.55
225/70R14.....	1,100	1,180	1,250	1,310	1,380	1,440	1,500	1,560	1,620	1,680	1,730	1,780	1,830	6	35.12	8.85
195/70R15.....	890	950	1,010	1,070	1,120	1,170	1,220	1,270	1,320	1,360	1,410	1,450	1,490	5½	33.34	7.75
205/70R15.....	950	1,010	1,070	1,130	1,190	1,240	1,300	1,350	1,400	1,440	1,490	1,540	1,580	5½	33.91	7.95
215/70R15.....	1,020	1,090	1,160	1,220	1,280	1,340	1,400	1,450	1,500	1,550	1,610	1,650	1,700	6	34.87	8.40
225/70R15.....	1,100	1,180	1,250	1,310	1,380	1,440	1,500	1,560	1,620	1,680	1,730	1,780	1,830	6	35.65	8.65

¹ The letter "H", "S" or "V" may be included in any specified tire size designation adjacent to the "R".
² Actual section width and overall width shall not exceed the specified section width by more than 7 percent.

TABLE I-U
TIRE LOAD RATINGS, TEST RIMS, MINIMUM SIZE FACTORS, AND SECTION WIDTHS FOR "60 SERIES" CANTILEVERED TIRES

Tire size designation ¹	Maximum tire loads (pounds) at various cold inflation pressures (p.s.i.)										Test rim width (inches)	Minimum size factor (inches)	Section width (inches)			
	16	18	20	22	24	26	28	30	32	34				36	38	40
B60C-13.....	780	840	890	930	980	1,030	1,070	1,110	1,150	1,190	1,230	1,270	1,300	4½	30.41	7.65
C60C-15.....	840	890	950	1,000	1,050	1,100	1,140	1,190	1,230	1,270	1,320	1,360	1,400	4	31.92	7.35

¹ The letters "H", "S" or "V" may be included in any specified tire size designation adjacent to the "dash".
² Actual section width and overall width shall not exceed the specified section width by more than 7 percent.

TABLE I-V
TIRE LOAD RATINGS, TEST RIMS, MINIMUM SIZE FACTORS, AND SECTION WIDTHS FOR "50 SERIES" BIAS PLY TIRES

Tire size designation ¹	Maximum tire loads (pounds) at various cold inflation pressures (p.s.i.)										Test rim width (inches)	Minimum size factor (inches)	Section width (inches)		
	16	18	20	22	24	26	28	30	32	34				36	38
BS0-13	780	840	890	930	980	1,030	1,070	1,110	1,150	1,190	1,230	1,270	1,300	30.84	9.15
CS0-13	840	890	950	1,000	1,050	1,100	1,140	1,190	1,230	1,270	1,320	1,360	1,400	3.48	9.40
DS0-13	890	950	1,010	1,070	1,120	1,170	1,220	1,270	1,320	1,360	1,410	1,450	1,490	32.29	9.85
FS0-14	1,020	1,090	1,160	1,220	1,280	1,340	1,400	1,450	1,500	1,550	1,610	1,650	1,700	34.10	10.20
GS0-14	1,100	1,180	1,250	1,310	1,380	1,440	1,500	1,560	1,620	1,690	1,730	1,780	1,830	35.29	10.95
HS0-14	1,200	1,290	1,360	1,440	1,510	1,580	1,650	1,710	1,770	1,830	1,890	1,950	2,010	36.24	11.35
MS0-14	1,420	1,520	1,616	1,700	1,780	1,860	1,940	2,020	2,090	2,160	2,230	2,300	2,370	38.51	12.55
NS0-14	1,500	1,600	1,700	1,790	1,880	1,970	2,050	2,130	2,210	2,280	2,360	2,430	2,500	39.17	12.85
FS0-15	950	1,010	1,070	1,130	1,190	1,240	1,300	1,350	1,400	1,440	1,490	1,540	1,580	33.74	9.50
GS0-15	1,100	1,180	1,250	1,310	1,380	1,440	1,500	1,560	1,620	1,680	1,730	1,780	1,830	35.38	10.35
HS0-15	1,200	1,290	1,360	1,440	1,510	1,580	1,650	1,710	1,770	1,830	1,890	1,950	2,010	36.76	11.15
LS0-15	1,340	1,430	1,520	1,600	1,680	1,750	1,830	1,900	1,970	2,040	2,100	2,170	2,230	31.94	11.65
NS0-15	1,500	1,600	1,700	1,790	1,880	1,970	2,050	2,130	2,210	2,280	2,360	2,430	2,500	39.65	12.65

¹ The letters "H", "S", or "V" may be included in any specified tire size designation adjacent to or in place of the "dash".
² Actual section width and overall width shall not exceed the specified section width by more than 7 percent.

TABLE I-W
TIRE LOAD RATINGS, TEST RIMS, MINIMUM SIZE FACTORS, AND SECTION WIDTHS FOR "50 SERIES" RADIAL PLY TIRES

Tire size designation ¹	Maximum tire loads (pounds) at various cold inflation pressures (p.s.i.)										Test rim width (inches)	Minimum size factor (inches)	Section width (inches)		
	16	18	20	22	24	26	28	30	32	34				36	38
BR50-13	780	840	890	930	980	1,030	1,070	1,110	1,150	1,190	1,230	1,270	1,300	30.84	9.15
CR50-13	840	890	950	1,000	1,050	1,100	1,140	1,190	1,230	1,270	1,320	1,360	1,400	31.48	9.40
GR50-14	1,100	1,180	1,250	1,310	1,380	1,440	1,500	1,560	1,620	1,680	1,730	1,780	1,830	35.29	10.95
JR50-14	1,260	1,350	1,430	1,500	1,580	1,650	1,720	1,790	1,860	1,920	1,980	2,040	2,100	36.74	11.60
GR50-15	1,100	1,180	1,250	1,310	1,380	1,440	1,500	1,560	1,620	1,680	1,730	1,780	1,830	35.38	10.35
HR50-15	1,200	1,290	1,360	1,440	1,510	1,580	1,650	1,710	1,770	1,830	1,890	1,950	2,010	36.76	11.15
JR50-15	1,260	1,350	1,430	1,500	1,580	1,650	1,720	1,780	1,860	1,920	1,980	2,040	2,100	37.24	11.35
LR50-15	1,340	1,430	1,520	1,600	1,680	1,750	1,820	1,900	1,970	2,040	2,100	2,170	2,230	37.94	11.65

¹ The letters "H", "S", or "V" may be included in any specified tire size designation adjacent to or in place of the "dash".
² Actual section width and overall width shall not exceed the specified section width by more than 7 percent.

TABLE I-X
TIRE LOAD RATINGS, TEST RIMS, MINIMUM SIZE FACTORS, AND SECTION WIDTHS FOR "50 SERIES" RADIAL PLY TIRES

Tire size designation ¹	Maximum tire loads (pounds) at various cold inflation pressures (p.s.i.)										Test rim width (inches)	Minimum size factor (inches)	Section ² width (inches)	
	16	18	20	22	24	26	28	30	32	34				36
195/50R15.....	650	690	730	770	810	850	890	920	955	990	1,020	1,050	1,080	7.91
225/50R16.....	880	940	1,000	1,060	1,110	1,160	1,210	1,255	1,300	1,345	1,390	1,435	1,475	8.98
285/50R15.....	1,260	1,350	1,430	1,500	1,580	1,650	1,720	1,790	1,860	1,920	1,980	2,040	2,100	11.26
265/50R16.....	1,160	1,235	1,310	1,385	1,450	1,520	1,580	1,645	1,709	1,765	1,820	1,875	1,930	10.71

¹ The letters "H", "S" or "V" may be included in any tire size designation adjacent to the "R".
² Actual section width and overall width shall not exceed the specified section width by more than 7 percent.

TABLE I-Y
TIRE LOAD RATINGS, TEST RIMS, MINIMUM SIZE FACTORS, AND SECTION WIDTHS FOR ALL MILLIMETRIC "65 SERIES" RADIAL PLY TIRES

Tire size designation ¹	Maximum tire loads (pounds) at various cold inflation pressures (p.s.i.)										Test rim width (inches)	Minimum size factor (inches)	Section ² width (inches)	
	16	18	20	22	24	26	28	30	32	34				36
195/65R350.....	815	860	905	950	990	1,030	1,070	1,115	1,155	1,195	1,235	1,275	1,315	7.48
205/65R375.....	920	970	1,020	1,070	1,120	1,170	1,220	1,265	1,310	1,355	1,400	1,445	1,490	7.76

¹ The letters "H", "S" or "V" may be included in any specified tire size designation adjacent to the "R".
² Actual section width and overall width shall not exceed the specified section width by more than 7 percent.

TABLE I-AA
TIRE LOAD RATINGS, TEST RIMS, MINIMUM SIZE FACTORS, AND SECTION WIDTHS FOR "P80" ISO TYPE TIRES

Tire size designation ¹	Maximum tire loads (pounds) at various cold inflation pressures (p.s.i.)										Test rim width (inches)	Minimum size factor (inches)	Section ² width (inches)	
	16	18	20	22	24	26	28	30	32	34				36
P155/80R13 ³	660	705	740	760	795	825	860	880	905	935	960	980	1,005	6.18

¹ The letters "H", "S" or "V" may be included in any specified tire size designation adjacent to the "R".
² Actual section width and overall width shall not exceed the specified section width by more than 7 percent.
³ The letters "D" for diagonal and "B" for belted may be used in place of the "R".

TABLE I-BB
TIRE LOAD RATINGS, TEST RIMS, MINIMUM SIZE FACTORS, AND SECTION WIDTHS FOR "40 SERIES" RADIAL-PLY TIRES

Tire size designation ¹	Maximum tire loads (pounds) at various cold inflation pressures (p.s.i.)										Test rim width (inches)	Minimum size factor (inches)	Section width (inches)		
	16	18	20	22	24	26	28	30	32	34				36	38
285/40R15.....	890	950	1,010	1,070	1,120	1,170	1,220	1,270	1,320	1,360	1,410	1,450	1,490	37.42	11.22

¹ The letters "H", "S" or "V" may be included in any tire size designation adjacent to the "R".
² Actual section width and overall width shall not exceed the specified section width by more than 7 percent.

TABLE I-CC
TIRE LOAD RATINGS, TEST RIMS, MINIMUM SIZE FACTORS, AND SECTION WIDTHS FOR "35 SERIES" RADIAL-PLY TIRES

Tire size designation ¹	Maximum tire loads (pounds) at various cold inflation pressures (p.s.i.)										Test rim width (inches)	Minimum size factor (inches)	Section width (inches)		
	16	18	20	22	24	26	28	30	32	34				36	38
345-35R15.....	960	1,030	1,090	1,150	1,210	1,270	1,320	1,370	1,420	1,470	1,520	1,560	1,610	37.42	13.58

¹ The letters "H", "S" or "V" may be included in any tire size designation adjacent to the "R".
² Actual section width and overall width shall not exceed the specified section width by more than 7 percent.

TABLE I-DD
TIRE LOAD RATINGS, TEST RIMS, MINIMUM SIZE FACTORS, AND SECTION WIDTHS FOR "55 SERIES" RADIAL-PLY TIRES

Tire size designation ¹	Maximum tire loads (pounds) at various cold inflation pressures (p.s.i.)										Test rim width (inches)	Minimum size factor (inches)	Section width (inches)		
	16	18	20	22	24	26	28	30	32	34				36	38
205/55R16.....	780	840	890	930	980	1,030	1,070	1,110	1,150	1,190	1,230	1,270	1,300	32.57	8.19
225/55R13.....	830	890	940	980	1,030	1,080	1,120	1,160	1,200	1,240	1,280	1,320	1,350	30.98	8.78

¹ The letters "H", "S" or "V" may be included in any tire size designation adjacent to the "R".
² Actual section width and overall width shall not exceed the specified section width by more than 7 percent.

TABLE I-EE
TIRE LOAD RATINGS, TEST RIMS, MINIMUM SIZE FACTORS, AND SECTION WIDTHS FOR "45 SERIES" RADIAL PLY TIRES

Tire size designation ¹	Maximum tire loads (pounds) at various cold inflation pressures (p.s.i.)										Test rim width (inches)	Minimum size factor (inches)	Section width (inches)			
	16	18	20	22	24	26	28	30	32	34				36	38	40
235/45R15.....	780	840	890	930	980	1,030	1,070	1,110	1,150	1,190	1,230	1,270	1,300	8	32.11	9.29

¹ The letters "H", "S" or "V" may be included in any tire size designation adjacent to the "R".
² Actual section width and overall width shall not exceed the specified section width by more than 7 percent.

TABLE I-FF
TIRE LOAD RATINGS, TEST RIMS, MINIMUM SIZE FACTORS, AND SECTION WIDTHS FOR "P/70 SERIES" ISO TYPE TIRES, STANDARD LOAD

Tire size designation ¹	Maximum tire loads (pounds) at various cold inflation pressures (p.s.i.)										Test rim width (inches)	Minimum size factor (inches)	Section width (inches)			
	16	18	20	22	24	26	28	30	32	34				36	38	40
P205/70R13 ³	870	925	980	1025	1070	1115	1155	1200	1235	1280	1310	1345	1390	5½	31.73	7.99

¹ The letters "H", "S" or "V" may be included in any specified tire size designation adjacent to the "R".
² Actual section width and overall width shall not exceed the specified section width by more than 7 percent.
³ The letters "D" for diagonal and "B" for belted may be used in place of the "R".

APPENDIX A (Continued)

**FEDERAL MOTOR VEHICLE
SAFETY STANDARD NO. 109**

TABLE II—MINIMUM BREAKING ENERGY VALUES (INCH-POUNDS)
TABLE II—A—FOR BIAS PLY TIRES WITH SIZE DESIGNATION OF 6.00 INCHES (OR 155 MILLIMETERS) AND ABOVE AND 70 SERIES TIRES

Cord material	Maximum permissible inflation pressure			
	32 lb/in ²	36 lb/in ²	40 lb/in ²	300 KPa
Rayon	1,650 in-lbs	2,574 in-lbs	3,300 in-lbs	1,650 in-lbs
Nylon or polyester	2,600 in-lbs	3,900 in-lbs	5,200 in-lbs	2,600 in-lbs

TABLE II—B—FOR BIAS PLY TIRES WITH SIZE DESIGNATION BELOW 6.00 INCHES (OR 155 MILLIMETERS)

Cord material	Maximum permissible inflation pressure			
	32 lb/in ²	36 lb/in ²	40 lb/in ²	300 KPa
Rayon	1,000 in-lbs	1,875 in-lbs	2,500 in-lbs	1,000 in-lbs
Nylon or polyester	1,950 in-lbs	2,925 in-lbs	3,900 in-lbs	1,950 in-lbs

TABLE II—C—FOR RADIAL PLY TIRES

Size designation	Maximum permissible inflation pressure			
	32 lb/in ²	36 lb/in ²	40 lb/in ²	300 KPa
Below 160 millimeters	1,950 in-lbs	2,925 in-lbs	3,900 in-lbs	1,950 in-lbs
160 millimeters or above	2,600 in-lbs	3,900 in-lbs	5,200 in-lbs	2,600 in-lbs

TABLE III—TEST INFLATION PRESSURES

	32 lb/in ²	36 lb/in ²	40 lb/in ²	300 KPa
Maximum permissible inflation pressure [(in pounds per square inch)]				
Pressure [(in pounds per square inch)] to be used in tests for physical dimensions, bead unseating, tire strength and tire endurance	24 lb/in ²	28 lb/in ²	32 lb/in ²	180 KPa
Pressure [(in pounds per square inch)] to be used in test or high speed performance	30 lb/in ²	34 lb/in ²	38 lb/in ²	220 KPa

[Next page is 161-1.]